

(12) INTERNATIONAL APPLICATION PUBLISHED UNDER THE PATENT COOPERATION TREATY (PCT)

(19) World Intellectual Property Organization
International Bureau



(43) International Publication Date
16 December 2004 (16.12.2004)

PCT

(10) International Publication Number
WO 2004/107964 A2

- (51) International Patent Classification⁷: A61B
- (21) International Application Number: PCT/US2004/018132
- (22) International Filing Date: 7 June 2004 (07.06.2004)
- (25) Filing Language: English
- (26) Publication Language: English
- (30) Priority Data:

60/476,584	6 June 2003 (06.06.2003)	US
60/478,040	11 June 2003 (11.06.2003)	US
60/478,704	13 June 2003 (13.06.2003)	US
60/478,657	13 June 2003 (13.06.2003)	US
60/478,682	13 June 2003 (13.06.2003)	US
60/507,689	30 September 2003 (30.09.2003)	US

- (72) Inventors; and
- (75) Inventors/Applicants (for US only): BRIGGS, Barry, Dean [US/US]; 2070 Anthony Drive, Campbell, CA 95008 (US). MARSOT, Travis [US/US]; 1072 East Meadow Circle, Palo Alto, CA 94303 (US). HEGENER, Jason [US/US]; 1072 East Meadow Circle, Palo Alto, CA 94303 (US). FREEMAN, Dominique, M. [GB/US]; 4545 La Honda Road, La Honda, CA 94020 (US). BOECKER, Dirk [DE/US]; 1652 Castilleja Avenue, Palo Alto, CA 94306 (US). ALDEN, Don [US/US]; 1312 Nelson Way, Sunnyvale, CA 94087 (US). SCHUMANN, Matt [GB/GB]; At the Old Horse Yard, Comberton Road Toft, Cambridge CB3 7RY (GB). BEADMAN, Mike [GB/GB]; At the Old Horse Yard, Comberton Road Toft, Cambridge CB3 7RY (GB).

- (71) Applicant (for all designated States except US): PE-LIKAN TECHNOLOGIES, INC. [US/US]; 1072 East Meadow Circle, Palo Alto, CA 94303 (US).
- (74) Agent: TUNG, Hao, Y.; Heller Ehrman White & McAuliffe LLP, 275 Middlefield Road, Menlo Park, CA 94025-3506 (US).

[Continued on next page]

(54) Title: METHOD AND APPARATUS FOR BODY FLUID SAMPLING AND ANALYTE SENSING

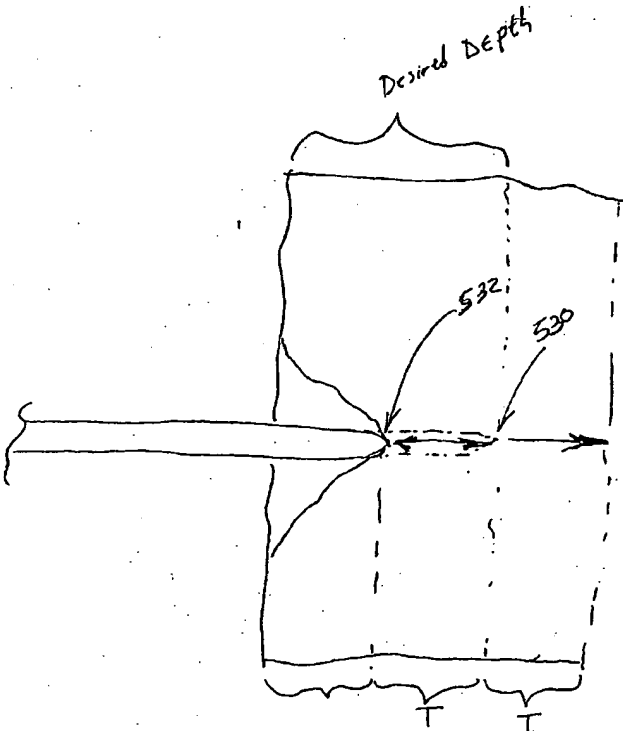

(57) Abstract: A method of controlling a penetrating member is provided. The method comprises providing a lancing device comprising a penetrating member driver having a position sensor and a processor that can determine the relative position and velocity of the penetrating member based on measuring relative position of the penetrating member with respect to time; providing a predetermined velocity control trajectory based on a model of the driver and a model of tissue to be contacted. In some embodiments, a feedforward control to maintain penetrating member velocity along said trajectory.

WO 2004/107964 A2

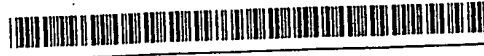

(81) Designated States (unless otherwise indicated, for every kind of national protection available): AE, AG, AI, AM, AT, AU, AZ, BA, BB, BG, BR, BW, BY, BZ, CA, CH, CN, CO, CR, CU, CZ, DE, DK, DM, DZ, EC, EE, EG, ES, FI, GB, GD, GE, GH, GM, HR, HU, ID, IL, IN, IS, JP, KE, KG, KP, KR, KZ, LC, LK, LR, LS, LT, LU, LV, MA, MD, MG, MK, MN, MW, MX, MZ, NA, NI, NO, NZ, OM, PG, PH, PL, PT, RO, RU, SC, SD, SE, SG, SK, SL, SY, TJ, TM, TN, TR, TT, TZ, UA, UG, US, UZ, VC, VN, YU, ZA, ZM, ZW.

(84) Designated States (unless otherwise indicated, for every kind of regional protection available): ARIPO (BW, GH, GM, KE, LS, MW, MZ, NA, SD, SL, SZ, TZ, UG, ZM,

ZW), Eurasian (AM, AZ, BY, KG, KZ, MD, RU, TJ, TM), European (AT, BE, BG, CH, CY, CZ, DE, DK, EE, ES, FI, FR, GB, GR, HU, IE, IT, LU, MC, NL, PL, PT, RO, SE, SI, SK, TR), OAPI (BF, BJ, CF, CG, CI, CM, GA, GN, GQ, GW, ML, MR, NE, SN, TD, TG).

Published:

— without international search report and to be republished upon receipt of that report

For two-letter codes and other abbreviations, refer to the "Guidance Notes on Codes and Abbreviations" appearing at the beginning of each regular issue of the PCT Gazette.

METHOD AND APPARATUS FOR BODY FLUID SAMPLING AND ANALYTE SENSING

BACKGROUND OF THE INVENTION

5 Lancing devices are known in the medical health-care products industry for piercing the skin to produce blood for analysis. Typically, a drop of blood for this type of analysis is obtained by making a small incision in the fingertip, creating a small wound, which generates a small blood droplet on the surface of the skin.

10 Early methods of lancing included piercing or slicing the skin with a needle or razor. Current methods utilize lancing devices that contain a multitude of spring, cam and mass actuators to drive the lancet. These include cantilever springs, diaphragms, coil springs, as well as gravity plumbs used to drive the lancet. The device may be held against the skin and mechanically triggered to ballistically launch the lancet.

15 Unfortunately, the pain associated with each lancing event using known technology discourages patients from testing. In addition to vibratory stimulation of the skin as the driver impacts the end of a launcher stop, known spring based devices have the possibility of firing lancets that harmonically oscillate against the patient tissue, causing multiple strikes due to recoil. This recoil and multiple strikes of the lancet is one major impediment to patient compliance with a structured glucose monitoring regime.

20 Another impediment to patient compliance is the lack of spontaneous blood flow generated by known lancing technology. In addition to the pain as discussed above, a patient may need more than one lancing event to obtain a blood sample since spontaneous blood generation is unreliable using known lancing technology. Thus the pain is multiplied by the number of attempts required by a patient to successfully
25 generate spontaneous blood flow. Different skin thickness may yield different results in terms of pain perception, blood yield and success rate of obtaining blood between different users of the lancing device. Known devices poorly account for these skin thickness variations.

30 Variations in skin thickness including the stratum corneum and hydration of the epidermis can yield different results between different users. Spontaneous blood droplet generation is dependent on reaching the blood capillaries and venuoles, which yield the blood sample. It is therefore an issue of correct depth of penetration of the cutting device. Due to variations in skin thickness and hydration, some types of skin will deform more

before cutting starts, and hence the actual depth of penetration will be less, resulting in less capillaries and venuoles cut and less spontaneous blood generation.

Known lancing devices fail to provide accurate sensing of lancet position. Thus they do not know exactly how far the penetrating member has cut into the tissue. This lack of position sensing is one reason for more painful lancing associated with known fluid sampling devices.

Additionally, known lancing devices fail to have sufficiently accurate control of lancet position and velocity to achieve a spontaneous blood generation in a relatively pain free manner.

10

SUMMARY OF THE INVENTION

The present invention provides solutions for at least some of the drawbacks discussed above. The technical field relates to the lancing of the finger to obtain a body fluid or blood sample for the analysis of that sample. Because the penetration distance is a strong predictor of the success of the lancing event for spontaneous blood generation, the ability of the device to accurately control this distance is of interest. Specifically, some embodiments of the present invention provide an improved body fluid sampling device. For some embodiments of penetrating member drivers, the invention provides improved methods for controlling the velocity and cutting efficient of a penetrating member. At least some of these and other objectives described herein will be met by embodiments of the present invention.

In one aspect, the present invention provides improved lancing devices operating with adaptive control algorithms. Because of the very high speeds that embodiments of the present invention may move their penetrating members, feedback control may not be sufficient, due to the short amount of time available. In one embodiment, the present invention provides desired parameters, based on the models of the penetrating member, the penetrating member driver, and the targeted tissue. Based on this model, the system may have predictive information stored in lookup tables on how to drive the penetrating member driver and when to apply braking force so that the device performs as desired to arrive at a desired depth and to provide a desired level of cutting efficiency and/or performance.

30

In one embodiment, a method of controlling a penetrating member is provided. The method comprises providing a lancing device having a penetrating member driver with a position sensor and a processor that can determine the relative position and velocity of the penetrating member based on measuring relative position of the penetrating member with respect to time; providing a look up table having desired velocity trajectory based on empirical data; and using control to adjust lancet velocity to maintain penetrating member velocity along said trajectory.

In another embodiment, the present invention relates to the way that an electronically driven lancing device controls the trajectory of the inbound lancet up to the point of maximum extension or penetration into a target tissue. This is the point of maximum penetration of the lancet into the skin. This embodiment of the present invention comprises a control algorithm, that when combined with the necessary hardware to execute the control instructions, increases the depth accuracy of the penetrating member. The present invention also provides improved cutting efficiency by providing lancet behavior that is optimized for cutting tissue.

In one aspect, the present invention involves learning through testing what the ideal setup parameters are and then using more complicated feedback systems to get results similar to a feed-forward system.

In other aspects, the present invention may involve manual braking, braking with zero residual energy, braking only, preserving acceleration, and appropriate force for smart braking.

The system may further comprise means for coupling the force generator with one of the penetrating members.

The system may further comprise a penetrating member sensor positioned to monitor a penetrating member coupled to the force generator, the penetrating member sensor configured to provide information relative to a depth of penetration of a penetrating member through a skin surface.

The depth of penetration may be about 100 to 2500 microns.

The depth of penetration may be about 500 to 750 microns.

The depth of penetration may be, in this nonlimiting example, no more than about 1000 microns beyond a stratum corneum thickness of a skin surface.

The depth of penetration may be no more than about 500 microns beyond a stratum corneum thickness of a skin surface.

The depth of penetration may be no more than about 300 microns beyond a stratum corneum thickness of a skin surface.

5 The depth of penetration may be less than a sum of a stratum corneum thickness of a skin surface and 400 microns.

The penetrating member sensor may be further configured to control velocity of a penetrating member.

10 The active penetrating member may move along a substantially linear path into the tissue.

The active penetrating member may move along an at least partially curved path into the tissue.

The driver may be a voice coil drive force generator.

The driver may be a rotary voice coil drive force generator.

15 The penetrating member sensor may be coupled to a processor with control instructions for the penetrating member driver.

The processor may include a memory for storage and retrieval of a set of penetrating member profiles utilized with the penetrating member driver.

20 The processor may be utilized to monitor position and speed of a penetrating member as the penetrating member moves in a first direction.

The processor may be utilized to adjust an application of force to a penetrating member to achieve a desired speed of the penetrating member.

25 The processor may be utilized to adjust an application of force to a penetrating member when the penetrating member contacts a target tissue so that the penetrating member penetrates the target tissue within a desired range of speed.

The processor may be utilized to monitor position and speed of a penetrating member as the penetrating member moves in the first direction toward a target tissue, wherein the application of a launching force to the penetrating member is controlled based on position and speed of the penetrating member.

30 The processor may be utilized to control a withdraw force to the penetrating member so that the penetrating member moves in a second direction away from the target tissue.

In the first direction, the penetrating member may move toward the target tissue at a speed that is different than a speed at which the penetrating member moves away from the target tissue.

5 In the first direction the penetrating member may move toward the target tissue at a speed that is greater than a speed at which the penetrating member moves away from the target tissue.

The speed of a penetrating member in the first direction may be the range of about 2.0 to 10.0 m/sec.

10 The average velocity of the penetrating member during a tissue penetration stroke in the first direction may be about 100 to about 1000 times greater than the average velocity of the penetrating member during a withdrawal stroke in a second direction.

A further understanding of the nature and advantages of the invention will become apparent by reference to the remaining portions of the specification and drawings.

15

BRIEF DESCRIPTION OF THE DRAWINGS

Figure 1 illustrates an embodiment of a controllable force driver in the form of a cylindrical electric penetrating member driver using a coiled solenoid -type configuration.

20 Figure 2A illustrates a displacement over time profile of a penetrating member driven by a harmonic spring/mass system.

Figure 2B illustrates the velocity over time profile of a penetrating member driver by a harmonic spring/mass system.

25 Figure 2C illustrates a displacement over time profile of an embodiment of a controllable force driver.

Figure 2D illustrates a velocity over time profile of an embodiment of a controllable force driver.

Figure 3 is a diagrammatic view illustrating a controlled feed-back loop.

30 Figure 4 is a perspective view of a tissue penetration device having features of the invention.

Figure 5 is an elevation view in partial longitudinal section of the tissue penetration device of Figure 4.

Figure 6 shows one embodiment of the present invention with a front end and landing a target tissue.

Figure 7 are graphs showing tenting and force related to a lancing event.

Figure 8-9 show schematics for a tissue penetrating device.

5 Figure 10 shows a graph of tenting and penetration profiles.

Figures 11A-11G shows a method of penetrating tissue.

Figures 12A-12C show various embodiments of a tissue penetrating device.

Figures 13-15 show graphs of penetrating member velocity over time.

10 Figure 16 shows a schematic representation of the reperfusion of skin after impact.

Figure 17 shows a tissue penetration device piercing skin.

Figures 18-21 are images of penetrating members and their interaction with tissue.

15 Figures 22-23 show various control methods as illustrated in graphs of velocity over time.

Figures 24-25 show schematics of embodiments of a penetrating member device with a controller to account for pressure.

Figure 26 shows a penetrating member in tissue.

Figure 27 shows another embodiment of a slug for use with the present invention.

20 Figure 28 shows a graph of force and displacement.

Figure 29 shows a graph of electrical performance.

Figure 30 shows a zero position for a solenoid driver.

Figures 31-43 show various graphs of penetrating member performance and control schematics.

25 Figure 44 shows a graph of penetrating member velocity versus time for one embodiment of a control algorithm according to the present invention.

Figure 45-46 shows one embodiment of a electroic drive mechanism.

Figures 47-53 show various graphs of penetrating member performance and control schematics.

30 Figures 54-56 shows various embodiments of penetrating member drivers.

Figures 57 and 58 show graph of performance.

Figure 59 shows one embodiment of disc for use with the present invention.

Figure 60 shows one view of the disc in a penetrating member device.

Figure 61 shows another embodiment of a device that may use a disc as described in Figure 59.

5

DESCRIPTION OF THE SPECIFIC EMBODIMENTS

The present invention provides a multiple analyte detecting member solution for body fluid sampling. Specifically, some embodiments of the present invention provides a multiple analyte detecting member and multiple penetrating member solution to measuring analyte levels in the body. The invention may use a high density design. It may use penetrating members of smaller size, such as but not limited to diameter or length, than known lancets. The device may be used for multiple lancing events without having to remove a disposable from the device. The invention may provide improved sensing capabilities. At least some of these and other objectives described herein will be met by embodiments of the present invention.

10

It is to be understood that both the foregoing general description and the following detailed description are exemplary and explanatory only and are not restrictive of the invention, as claimed. It must be noted that, as used in the specification and the appended claims, the singular forms "a", "an" and "the" include plural referents unless the context clearly dictates otherwise. Thus, for example, reference to "a material" may include mixtures of materials, reference to "a chamber" may include multiple chambers, and the like. References cited herein are hereby incorporated by reference in their entirety, except to the extent that they conflict with teachings explicitly set forth in this specification.

15

In this specification and in the claims which follow, reference will be made to a number of terms which shall be defined to have the following meanings:

20

"Optional" or "optionally" means that the subsequently described circumstance may or may not occur, so that the description includes instances where the circumstance occurs and instances where it does not. For example, if a device optionally contains a feature for analyzing a blood sample, this means that the analysis feature may or may not be present, and, thus, the description includes structures wherein a device possesses the analysis feature and structures wherein the analysis feature is not present.

25

30

The present invention may be used with a variety of different penetrating member drivers. It is contemplated that these penetrating member drivers may be spring based, solenoid based, magnetic driver based, nanomuscle based, or based on any other mechanism useful in moving a penetrating member along a path into tissue. It should be noted that the present invention is not limited by the type of driver used with the penetrating member feed mechanism. One suitable penetrating member driver for use with the present invention is shown in Figure 1. This is an embodiment of a solenoid type electromagnetic driver that is capable of driving an iron core or slug mounted to the penetrating member assembly using a direct current (DC) power supply. The electromagnetic driver includes a driver coil pack that is divided into three separate coils along the path of the penetrating member, two end coils and a middle coil. Direct current is alternated to the coils to advance and retract the penetrating member. Although the driver coil pack is shown with three coils, any suitable number of coils may be used, for example, 4, 5, 6, 7 or more coils may be used.

Referring to the embodiment of Figure 1, the stationary iron housing 10 may contain the driver coil pack with a first coil 12 flanked by iron spacers 14 which concentrate the magnetic flux at the inner diameter creating magnetic poles. The inner insulating housing 16 isolates the penetrating member 18 and iron core 20 from the coils and provides a smooth, low friction guide surface. The penetrating member guide 22 further centers the penetrating member 18 and iron core 20. The penetrating member 18 is protracted and retracted by alternating the current between the first coil 12, the middle coil, and the third coil to attract the iron core 20. Reversing the coil sequence and attracting the core and penetrating member back into the housing retracts the penetrating member. The penetrating member guide 22 also serves as a stop for the iron core 20 mounted to the penetrating member 18.

As discussed above, tissue penetration devices which employ spring or cam driving methods have a symmetrical or nearly symmetrical actuation displacement and velocity profiles on the advancement and retraction of the penetrating member as shown in Figures 2 and 3. In most of the available lancet devices, once the launch is initiated, the stored energy determines the velocity profile until the energy is dissipated. Controlling impact, retraction velocity, and dwell time of the penetrating member within the tissue can be useful in order to achieve a high success rate while accommodating

variations in skin properties and minimize pain. Advantages can be achieved by taking into account of the fact that tissue dwell time is related to the amount of skin deformation as the penetrating member tries to puncture the surface of the skin and variance in skin deformation from patient to patient based on skin hydration.

5 In this embodiment, the ability to control velocity and depth of penetration may be achieved by use of a controllable force driver where feedback is an integral part of driver control. Such drivers can control either metal or polymeric penetrating members or any other type of tissue penetration element. The dynamic control of such a driver is illustrated in Figure. 2C which illustrates an embodiment of a controlled displacement
10 profile and Figure 2D which illustrates an embodiment of a the controlled velocity profile. These are compared to Figures 2A and 2B, which illustrate embodiments of displacement and velocity profiles, respectively, of a harmonic spring/mass powered driver. Reduced pain can be achieved by using impact velocities of greater than about 2
15 m/s entry of a tissue penetrating element, such as a lancet, into tissue. Other suitable embodiments of the penetrating member driver are described in commonly assigned, copending U.S. Patent Application Ser. No. 10/127,395, (Attorney Docket No. 38187-2551) filed April 19, 2002 and previously incorporated herein.

Figure 3 illustrates the operation of a feedback loop using a processor 60. The processor 60 stores profiles 62 in non-volatile memory. A user inputs information 64
20 about the desired circumstances or parameters for a lancing event. The processor 60 selects a driver profile 62 from a set of alternative driver profiles that have been preprogrammed in the processor 60 based on typical or desired tissue penetration device performance determined through testing at the factory or as programmed in by the operator. The processor 60 may customize by either scaling or modifying the profile
25 based on additional user input information 64. Once the processor has chosen and customized the profile, the processor 60 is ready to modulate the power from the power supply 66 to the penetrating member driver 68 through an amplifier 70. The processor 60 may measure the location of the penetrating member 72 using a position sensing mechanism 74 through an analog to digital converter 76 linear encoder or other such
30 transducer. Examples of position sensing mechanisms have been described in the embodiments above and may be found in the specification for commonly assigned, copending U.S. Patent Application Ser. No. 10/127,395, (Attorney Docket No. 38187-

2551) filed April 19, 2002 and previously incorporated herein. The processor 60 calculates the movement of the penetrating member by comparing the actual profile of the penetrating member to the predetermined profile. The processor 60 modulates the power to the penetrating member driver 68 through a signal generator 78, which may control the amplifier 70 so that the actual velocity profile of the penetrating member does not exceed the predetermined profile by more than a preset error limit. The error limit is the accuracy in the control of the penetrating member.

After the lancing event, the processor 60 can allow the user to rank the results of the lancing event. The processor 60 stores these results and constructs a database 80 for the individual user. Using the database 79, the processor 60 calculates the profile traits such as degree of painlessness, success rate, and blood volume for various profiles 62 depending on user input information 64 to optimize the profile to the individual user for subsequent lancing cycles. These profile traits depend on the characteristic phases of penetrating member advancement and retraction. The processor 60 uses these calculations to optimize profiles 62 for each user. In addition to user input information 64, an internal clock allows storage in the database 79 of information such as the time of day to generate a time stamp for the lancing event and the time between lancing events to anticipate the user's diurnal needs. The database stores information and statistics for each user and each profile that particular user uses.

In addition to varying the profiles, the processor 60 can be used to calculate the appropriate penetrating member diameter and geometry suitable to realize the blood volume required by the user. For example, if the user requires about 1-5 microliter volume of blood, the processor 60 may select a 200 micron diameter penetrating member to achieve these results. For each class of lancet, both diameter and lancet tip geometry, is stored in the processor 60 to correspond with upper and lower limits of attainable blood volume based on the predetermined displacement and velocity profiles.

The lancing device is capable of prompting the user for information at the beginning and the end of the lancing event to more adequately suit the user. The goal is to either change to a different profile or modify an existing profile. Once the profile is set, the force driving the penetrating member is varied during advancement and retraction to follow the profile. The method of lancing using the lancing device comprises selecting a profile, lancing according to the selected profile, determining

lancing profile traits for each characteristic phase of the lancing cycle, and optimizing profile traits for subsequent lancing events.

Figure 4 illustrates an embodiment of a tissue penetration device, more specifically, a lancing device 80 that includes a controllable driver 179 coupled to a tissue penetration element. The lancing device 80 has a proximal end 81 and a distal end 5 82. At the distal end 82 is the tissue penetration element in the form of a penetrating member 83, which is coupled to an elongate coupler shaft 84 by a drive coupler 85. The elongate coupler shaft 84 has a proximal end 86 and a distal end 87. A driver coil pack 88 is disposed about the elongate coupler shaft 84 proximal of the penetrating member 83. A position sensor 91 is disposed about a proximal portion 92 of the elongate coupler shaft 84 and an electrical conductor 94 electrically couples a processor 93 to the position sensor 91. The elongate coupler shaft 84 driven by the driver coil pack 88 controlled by the position sensor 91 and processor 93 form the controllable driver, specifically, a controllable electromagnetic driver. 10

Referring to Figure 5, the lancing device 80 can be seen in more detail, in partial longitudinal section. The penetrating member 83 has a proximal end 95 and a distal end 96 with a sharpened point at the distal end 96 of the penetrating member 83 and a drive head 98 disposed at the proximal end 95 of the penetrating member 83. A penetrating member shaft 201 is disposed between the drive head 98 and the sharpened point 97. 15 The penetrating member shaft 201 may be comprised of stainless steel, or any other suitable material or alloy and have a transverse dimension of about 0.1 to about 0.4 mm. The penetrating member shaft may have a length of about 3 mm to about 50 mm, specifically, about 15 mm to about 20 mm. The drive head 98 of the penetrating member 83 is an enlarged portion having a transverse dimension greater than a transverse 20 dimension of the penetrating member shaft 201 distal of the drive head 98. This configuration allows the drive head 98 to be mechanically captured by the drive coupler 85. The drive head 98 may have a transverse dimension of about 0.5 to about 2 mm. 25

A magnetic member 102 is secured to the elongate coupler shaft 84 proximal of the drive coupler 85 on a distal portion 203 of the elongate coupler shaft 84. The magnetic member 102 is a substantially cylindrical piece of magnetic material having an axial lumen 204 extending the length of the magnetic member 102. The magnetic member 102 has an outer transverse dimension that allows the magnetic member 102 to 30

slide easily within an axial lumen 105 of a low friction, possibly lubricious, polymer guide tube 105' disposed within the driver coil pack 88. The magnetic member 102 may have an outer transverse dimension of about 1.0 to about 5.0 mm, specifically, about 2.3 to about 2.5 mm. The magnetic member 102 may have a length of about 3.0 to about 5.0 mm, specifically, about 4.7 to about 4.9 mm. The magnetic member 102 can be made from a variety of magnetic materials including ferrous metals such as ferrous steel, iron, ferrite, or the like. The magnetic member 102 may be secured to the distal portion 203 of the elongate coupler shaft 84 by a variety of methods including adhesive or epoxy bonding, welding, crimping or any other suitable method.

Proximal of the magnetic member 102, an optical encoder flag 206 is secured to the elongate coupler shaft 84. The optical encoder flag 206 is configured to move within a slot 107 in the position sensor 91. The slot 107 of the position sensor 91 is formed between a first body portion 108 and a second body portion 109 of the position sensor 91. The slot 107 may have separation width of about 1.5 to about 2.0 mm. The optical encoder flag 206 can have a length of about 14 to about 18 mm, a width of about 3 to about 5 mm and a thickness of about 0.04 to about 0.06 mm.

The optical encoder flag 206 interacts with various optical beams generated by LEDs disposed on or in the position sensor body portions 108 and 109 in a predetermined manner. The interaction of the optical beams generated by the LEDs of the position sensor 91 generates a signal that indicates the longitudinal position of the optical flag 206 relative to the position sensor 91 with a substantially high degree of resolution. The resolution of the position sensor 91 may be about 200 to about 400 cycles per inch, specifically, about 350 to about 370 cycles per inch. The position sensor 91 may have a speed response time (position/time resolution) of 0 to about 120,000 Hz, where one dark and light stripe of the flag constitutes one Hertz, or cycle per second. The position of the optical encoder flag 206 relative to the magnetic member 102, driver coil pack 88 and position sensor 91 is such that the optical encoder 91 can provide precise positional information about the penetrating member 83 over the entire length of the penetrating member's power stroke.

An optical encoder that is suitable for the position sensor 91 is a linear optical incremental encoder, model HEDS 9200, manufactured by Agilent Technologies. The model HEDS 9200 may have a length of about 20 to about 30 mm, a width of about 8 to

about 12 mm, and a height of about 9 to about 11 mm. Although the position sensor 91 illustrated is a linear optical incremental encoder, other suitable position sensor embodiments could be used, provided they possess the requisite positional resolution and time response. The HEDS 9200 is a two channel device where the channels are 90 degrees out of phase with each other. This results in a resolution of four times the basic cycle of the flag. These quadrature outputs make it possible for the processor to determine the direction of penetrating member travel. Other suitable position sensors include capacitive encoders, analog reflective sensors, such as the reflective position sensor discussed above, and the like.

10 A coupler shaft guide 111 is disposed towards the proximal end 81 of the lancing device 80. The guide 111 has a guide lumen 112 disposed in the guide 111 to slidably accept the proximal portion 92 of the elongate coupler shaft 84. The guide 111 keeps the elongate coupler shaft 84 centered horizontally and vertically in the slot 102 of the optical encoder 91.

15 In another aspect of the present invention, this solution involves using two measurements, tenting and force present at the front end of the lancing device 200, to interpolate the stratum corneum (SC) thickness at that particular skin location. It is known that force applied to the front end of a lancing device affects the amount of tenting caused by an inbound lancet. This effect can be visualized by plotting force vs. tenting on a linear scale. Varying Stratum Corneum thickness causes a change in the slope of this curve. This data can be used to interpolate an SC thickness value.

20 Referring now to Figure 6, one embodiment of a lancing device 200 is shown. The arrow 202 indicates that a penetrating member will move outward to penetrate tissue. A finger (shown in phantom) will press against the front end 204 which is coupled to a pressure transducer 206. This may in turn be coupled to a processor 208. The pressure transducer 206 may be any one known in the art such as but not limited to a strain gauge or a piezoelectric sensor. The processor 208 may be coupled to memory M that stores readings.

30 Referring now to Figure 7, experiment 342 shows that there are two different slopes 220 and 222 for different SC thicknesses. Line 222 corresponds to the thicker (313) SC while line 220 corresponds to the thinner (217) SC. Thus in the lancing device 200, by recording the force (which will undoubtedly vary) applied by the user and the

tenting, the SC thickness can be determined based on the slope of the line. Methods for determining tenting are discussed in commonly assigned, copending U.S. Patent Application Ser. No. 60/476,584 (Attorney Docket No. 38187-2677) may be used with the present invention. It should be understood that this information may be stored into the memory. The location used to lance may also be stored into memory M so that measurements for specific sites may be grouped together.

5 It should be understood that the present invention relates to the way that an electronically driven lancing device controls the trajectory of the inbound lancet up to the point of maximum extension. This is the point of maximum penetration of the lancet into the skin. In one embodiment, the invention comprises a control algorithm, that when combined with the suitable hardware to execute the control instructions, increases the depth accuracy. The present application also describes the method of a quiet phase but only refers to traditional braking adjustment after this phase. The present application also describes the idea of setting the contact velocity at a rate where coil activity is minimized and the control system "operates within a projected trajectory."

15 Referring now to Figure 8, one method of penetrating member control will be described. The method of lancing starts with the penetrating member control system 310 that is coupled to an electric drive mechanism 320 used to accelerate the penetrating member 322 to a desired speed toward a target tissue T. The penetrating member 322 hits the skin at a relative point and then there is a switch when the penetrating member 322 reaches a certain displacement. The control system will cause the braking to come on. And then braking will happen really kind of a nondeterministic way. The brakes are on, it goes to a certain depth. There is not an interactiveness with the control system as to where the member 322 is at, as to where it needs to be (from the point the braking switches on). The variance of where the member 322 is and where it wants to be is could be improved.

25 Referring now to Figure 9, with the present invention using one embodiment of what is termed "smart braking", an adaptive control system 350 may be used to improve performance. Such a system 350 has the ability to redirect braking during the braking period to get to the member 322 to the appropriate depth desired. In one embodiment, it is not necessarily a full-on braking up to the point of reversal in a binary manner (i.e. either full on or full off).

In one embodiment of adaptive control system 350, variable braking force, which is computationally more complex, may be used. In one embodiment, for each duty cycle that the penetrating member 322 is braking, the system 350 will look where the member 322 is, and where it should be. There may be a look up table used to determine if the member 322 is under or over the place where the member 322 wants to be for a particular part of the braking cycle. The control system 350 can redirect or adjust braking (e.g. not as hard or harder in the next braking cycle). A position encoder 356 is used with the system 350.

In a still further embodiment of the present invention, a more complex processor may be used with the system 350. In this embodiment, rather than just a lookup table, the processor in control system 350 can calculate the level of deceleration and maybe make that relative to the contact point, so that you do not need to do an integration of the curve. Instead of using a ton of lookup tables, the system 350 can direct the lancet with a more elegant algorithm.

In still other embodiments, the control system 350 may be paired with an improved position sensor. If the processor desires a certain amount of data to make a predictive decision within the braking segment, the amount of position feedback to the processor may be increased. It may be that you may not have enough predictive ability because the control system is limited or it comes too late. The penetrating member 322 may already have gone too far or the controller is too slow to make the change. Accordingly, an improved position sensor may provide more position data. The data may arrive faster and it may be more precise as to the location of the penetrating member.

From a conceptual standpoint, it would be possible to further improve control system performance. As discussed, the position encoder would be improved. The clock speed of the processor would be faster to handle the additional flow of data because it comes faster. Finer control of the solenoid or other electronic drive mechanism may also be desired so that solenoid can move the penetrating member at a level of accuracy matching or coming close to that of the position encoder.

Optimally, the present invention provides for controlling the trajectory of the inbound lancet up to the point of maximum extension with an adaptive algorithm. With regards to the algorithm, in one embodiment, there is a decision point when the

penetrating member 322 is still traveling in the inbound direction. With stored up data, based on this time and this position and a desired depth or profile, the control system 350 will make a decision whether to accelerate, brake, or do nothing. The decision point will ultimately determine what depth the penetrating member 322 reaches. It should be understood of course that there may be more than one decision point in a braking cycle. But if the deceleration is too high or other factors excessively slow the member 322, the control system 350 may choose to accelerate rather than brake. It could also brake harder, as the circumstances warrant.

It should also be understood that it may be possible to bring down the variance where the lancet ultimately ends up. For a certain depth, there is an optimal contact speed, given the uncertainty once the penetrating member 322 goes past initial contact with the tissue. It helps that the entire control system, in that it gives a neutral composition. There may be some braking or some acceleration, but there is not a huge amount of correction. There is a neutral position.

In one embodiment, if the braking algorithm is more complex in the sense that instead of just looking at position and time, it is looking at position and time for the last three cycles and dividing that into a smooth braking factor and taking that's distance (or corrected distance based on the contact point routine), then it is a simple multiplication of this factor and that position factor and that the system does not need a true update at the next look up table interval. It is a rolling average that gets the penetrating member to the intended depth at a higher degree of accuracy.

There is some variability with how the skin performs. Physiologically, as a nonlimiting example, a stick of about 2 mm in depth might increase the actual depth by +/- 300 microns. Even though theoretically, the system can get really close to the desired depth with the control system, other mechanical or physiological reasons may create errors. Smarter braking increase the stability of the control system. It might have a more stable profile to deal with physiological uncertainties that are otherwise unaccounted for.

Various velocity profiles can influence cutting efficiency and more specifically, a final depth as the tissue reacts differently based on velocity of the penetrating member. As a nonlimiting example, if the penetrating members goes in fast and is braked hard, the tissue may still have momentum and the tissue/lancet interface may not be stable (i.e. not

move together), and it might end up being that the composition of the tissue plays more of a factor. If you had a more stable control, the physiological variability of the tissue could be reduced or substantially taken out of the equation. In one embodiment of the present invention, the control tends to adjust the braking cycle so that the rate of
5 deceleration is relatively constant and keeps the tissue or skin in a state where it does not have any unfair loads put on it. If the braking occurs too suddenly, the skin can bound away from the lancet and be keep moving.

Other improved embodiments of the control system, in addition to accounting for position and velocity, they may also account for trajectory. In one embodiment, the ideal
10 lancing algorithm involves driving the lancet at a high rate of velocity to a predetermined depth, stopping at a given distance, and pulling out the lancet at a given rate. By achieving a contact speed, the device can meter the amount of force it presents to the skin at impact. This contact speed will be higher for a lancing cycle in which a higher penetration depth is intended. A velocity lookup table corresponding to the composite
15 amount (The average velocity necessary to achieve a certain depth through iteration of many sticks) is set as one of the directions to the control sequence. The decision to redirect the lancet should come late in the lancing cycle and should be relative to displacement, rather than velocity. If the lancet passes within a certain distance of the intended displacement, the velocity can be checked by the control processor, and
20 compared to a velocity lookup table.

As a nonlimiting example, 0.5 millimeters before the intended penetration distance, the speed is 30% of the contact speed. According to the velocity lookup table that is stored for this control algorithm and called at this displacement, the speed should be 30%. In this case, the control system does nothing to redirect the lancet. If the speed
25 was 20% of the contact speed, this would indicate to the device that the lancet had decelerated too much, and a metered burst of energy corresponding to its deviation would be applied to the lancet from the drive motor to accelerate lancet to its intended displacement. If the speed was 40% of the contact speed, the lancet would be decelerated with a metered burst of energy. Because a linear position sensor has better
30 position/time resolution at higher speeds and the ability of the motor to accelerate or decelerate is higher at low speeds, the decision to accelerate or brake should come at a displacement in which the velocity is consistently within the optimal working range of

the position encoder and the motor. It should also occur late enough in the lancing cycle to be predictive. There may be more than one position-based decision point while penetrating, but the processing speed, force response of the electronic motor, and resolution of the position sensor are the physical determinants of whether this is feasible for the system and within what range of positions this control methodology is effective.

A more complex control algorithm would also utilize a least squares method in tandem with the velocity and position comparison. In this embodiment, this binomial equation would determine the rate of deceleration and invoke the braking or acceleration algorithm with the additional factor concerning the shape of the curve. It would distinguish between skin stiffness and skin position by effectively integrating the velocity vs. position curve during the deceleration phase of the lancing cycle. An algorithm factors these variables and accounts for them during in the control loop will provide a more desirable result, in terms of cutting efficiency and desired penetrating depth of a penetrating member into tissue.

In yet another embodiment of the present invention, disclosure is provided herein that relates to a mode of operation with an electronic lancet drive system where the inbound penetration of the lancet to the skin is determined by the amount of force applied by the motor. Referring now to Figure 10, the graph shows lancing sticks or events into the same finger with different contact speeds. As seen in Figure 10, there is a strong correlation between speed and penetration. No feedback is applied to obtain a certain position. As seen in Figure 10, the repeatability of the depth appears to be high. There is also a relatively predictable way that the skin tents above a certain speed.

The current method concerning lancing involves driving the lancet at a high rate of velocity to a predetermined depth, stopping at a given distance, and pulling out the lancet at a given rate. In the present embodiment of the invention, the system involves an alternative control mode of operation where the intended depth is not held constant.

With electronic lancing and position feedback, the lancing device 20 can meter the amount of force it presents to the skin at impact. The contact speed will be higher for a lancing cycle in which a higher penetration depth is intended. In one embodiment, a velocity lookup table corresponding to the composite amount (the average velocity necessary to achieve a certain depth through iteration of many sticks) is set as one of the directions to the control sequence. There may be a desire not to exceed threshold of a

certain position in which the lancet control system intervenes and stops the lancet from penetrating further.

The tenting and penetration appeared to be more consistent than when feedback is applied. When the rate of a blade already cutting through a material is suddenly
5 changed, the cutting efficiency decreases and the blade binds. This may translate into increases in the amount and variance of deflection, or tenting, of the skin.

It should be understood that this type of setup may be advantageous mode for some users. This is true if the physiological characteristics that determine successful sampling hold more consistently with force applied rather than depth achieved. Successful
10 sampling is defined as a sufficient sample with a minimum of pain. The control system can introduce uncertainty for certain types of sticks by providing a position-based correction that does not need to occur. The device is not limited to this forced-based mode. Both force and position based control may be loaded on the same device.

Fixed contact point

15 Referring now to Figures 11A-11G, in one embodiment, the processor determines that the skin has been contacted when the end tip of the penetrating member has moved a predetermined distance with respect to its initial position. If the distance from the tip
961 of the penetrating member 183 to the target tissue 233 is known prior to initiation of penetrating member 183 movement, the initial position of the penetrating member 183 is
20 fixed and known, and the movement and position of the penetrating member 183 can be accurately measured during a lancing cycle, then the position and time of penetrating member contact can be determined. This method requires an accurate measurement of the distance between the penetrating member tip 196 and the patient's skin 233 when the
penetrating member 183 is in the zero time or initial position. This can be accomplished
25 in a number of ways. One way is to control all of the mechanical parameters that influence the distance from the penetrating member tip 196 to the patient's tissue or a surface of the lancing device 180 that will contact the patient's skin 233. This could include the start position of the magnetic member 202, magnetic path tolerance, magnetic member 202 dimensions, driver coil pack 188 location within the lancing
30 device 180 as a whole, length of the elongate coupling shaft 184, placement of the magnetic member 202 on the elongate coupling shaft 184, length of the penetrating member 183 etc. If all these parameters, as well as others can be suitably controlled in

manufacturing with a tolerance stack-up that is acceptable, then the distance from the penetrating member tip 196 to the target tissue 233 can be determined at the time of manufacture of the lancing device 180. The distance could then be programmed into the memory of the processor 193. If an adjustable feature is added to the lancing device 180, such as an adjustable length elongate coupling shaft 184, this can accommodate variations in all of the parameters noted above, except length of the penetrating member 183. An electronic alternative to this mechanical approach would be to calibrate a stored memory contact point into the memory of the processor 193 during manufacture based on the mechanical parameters described above.

10 In another embodiment, moving the penetrating member tip 196 to the target tissue 233 very slowly and gently touching the skin 233 prior to actuation can accomplish the distance from the penetrating member tip 196 to the tissue 233. The position sensor can accurately measure the distance from the initialization point to the point of contact, where the resistance to advancement of the penetrating member 183 stops the penetrating member movement. The penetrating member 183 is then retracted to the initialization point having measured the distance to the target tissue 233 without creating any discomfort to the user.

Using an acoustic signal to determine contact point

20 In yet another embodiment, the processor 193 determines skin 233 contact by the penetrating member 183 by detection of an acoustic signal produced by the tip 196 of the penetrating member 183 as it strikes the patient's skin 233. Detection of the acoustic signal can be measured by an acoustic detector 236 placed in contact with the patient's skin 233 adjacent a penetrating member penetration site 237, as shown in FIG. 31. Suitable acoustic detectors 236 include piezo electric transducers, microphones and the like. The acoustic detector 236 transmits an electrical signal generated by the acoustic signal to the processor 193 via electrical conductors 238.

Using continuity in an electric circuit to measure contact point

30 In another embodiment, contact of the penetrating member 183 with the patient's skin 233 can be determined by measurement of electrical continuity in a circuit that includes the penetrating member 183, the patient's finger 234 and an electrical contact pad 240 that is disposed on the patient's skin 233 adjacent the contact site 237 of the penetrating member 183. In this embodiment, as soon as the penetrating member 183

contacts the patient's skin 233, the circuit 239 is completed and current flows through the circuit 239. Completion of the circuit 239 can then be detected by the processor 193 to confirm skin 233 contact by the penetrating member 183. If the penetrating member 183 has not contacted the target skin 233, then the process proceeds to a timeout operation.

5 In the timeout operation, the processor 193 waits a predetermined time period. If the timeout period has not yet elapsed (a "No" outcome from the decision box 267), then the processor continues to monitor whether the penetrating member has contacted the target skin 233. The processor 193 preferably continues to monitor the position and speed of the penetrating member 183, as well as the electrical current to the appropriate coil 214-

10 217 to maintain the desired penetrating member 183 movement. If the timeout period elapses without the penetrating member 183 contacting the skin (a "Yes" output from the decision box 267), then it is deemed that the penetrating member 183 will not contact the skin and the process proceeds to a withdraw phase, where the penetrating member is withdrawn away from the skin 233, as discussed more fully below. The penetrating

15 member 183 may not have contacted the target skin 233 for a variety of reasons, such as if the patient removed the skin 233 from the lancing device or if something obstructed the penetrating member 183 prior to it contacting the skin.

Reduction in penetrating member velocity to determine contact point

In another embodiment, the processor 193 may use software to determine

20 whether the penetrating member 183 has made contact with the patient's skin 233 by measuring for a sudden reduction in velocity of the penetrating member 183 due to friction or resistance imposed on the penetrating member 183 by the patient's skin 233. The optical encoder 191 measures displacement of the penetrating member 183. The position output data provides input to the interrupt input of the processor 193. The

25 processor 193 also has a timer capable of measuring the time between interrupts. The distance between interrupts is known for the optical encoder 191, so the velocity of the penetrating member 183 can be calculated by dividing the distance between interrupts by the time between the interrupts. This method requires that velocity losses to the penetrating member 183 and elongate coupler 184 assembly due to friction are known to

30 an acceptable level so that these velocity losses and resulting deceleration can be accounted for when establishing a deceleration threshold above which contact between penetrating member tip 196 and target tissue 233 will be presumed.

This same concept can be implemented in many ways. For example, rather than monitoring the velocity of the penetrating member 183, if the processor 193 is controlling the penetrating member driver in order to maintain a fixed velocity, the power to the driver 188 could be monitored. If an amount of power above a predetermined threshold is required in order to maintain a constant velocity, then contact between the tip of the penetrating member 196 and the skin 233 could be presumed. All of the above figures are in reference to figures found in U.S. Patent Application Ser. No. 10/127,395 (Attorney Docket No. 38187-2551US).

Using a slow moving penetrating member to determine contact point
In a still further embodiment, a new contact point algorithm is run before the actual lance event. As a nonlimiting example, such an algorithm may be run immediately prior to lancing.

Whether the penetrating member is striking a finger or other material/object can be determined. Information about the skin properties of the finger can be determined. With a reasonable sized aperture, the finger contact point can vary by more than the depth of penetration. Unless the contact point can be accurately determined, correct depth may be difficult to control. This method cancels out mechanical variations that occur in the manufacturing process of the actuator, coupling to the penetrating member, and length of the penetrating member. In addition, we can determine if there is anything there at all (strike into air). The finger in the above description can be any part of the body to be lanced.

Description of the algorithm: In one embodiment, the penetrating member is accelerated to a slow speed, in the present embodiment of the actuator, it is about 0.6 to 0.8 meters/second. It should be understood that this is a nonlimiting example. The speed may be tuned to the mass of the lancing assembly. The more the mass of the assembly, the slower the speed should be. Since the energy stored in the assembly is determined by $\frac{1}{2} MV^2$, the desire is to store a sufficiently small amount of energy such that the penetrating member does not penetrate or does not significantly penetrate the stratum corneum of the skin.

Referring now to Figure 12A-12C, the speed of the penetrating member is maintained at the desired velocity until the Start Contact Search Point 400 is reached. In the present embodiment, this is simply first point before the contact can occur. The coil

power is turned off when the Start Contact Search Point is reached, and the penetrating member assembly coasts. In one embodiment, this Start Contact Search Point may be where the front end of the device is located.

Unimpeded, the penetrating member assembly in this present embodiment of the invention will coast until the Stop Contact Search Point is reached 402. In the present embodiment, this is simply the maximum point at which a finger can be placed for a valid strike to be achieved. Since the penetrating member assembly has a maximum depth limited by the physical stop, unless there is enough depth available (maximum depth-contact point has to be $>$ desired depth) there is no reason to continue the stick. This is also the way it is determined that the penetrating member would strike into air.

While coasting, a base speed of the penetrating member at the beginning of the Start Contact Search Point is established and the speed of the penetrating member assembly is monitored. Position feedback and monitoring is discussed in commonly assigned copending U.S. Patent Application Ser. No. 10/127,395 (Attorney Docket No. 38187-2551) filed April 19, 2002, fully incorporated herein by reference. When a slowdown of more than a preset threshold (in one embodiment, we have found that about 12.5% seems to work fine), the distance at which this occurs is recorded. In one embodiment, this distance may be recorded in the processor or in memory coupled to a processor. This is called the tentative contact point 404. Using a quadrature phase sensor in one embodiment of the present invention or other sensor, we can measure direction. The coasting continues until a reversal of direction or a timeout occurs with no reversal. In one embodiment, if no reversal occurs, we may assume that either binding in the mechanical assembly occurred or the penetrating member struck something that did not rebound. This is called a stall.

If a reversal of direction occurs, we store this value or distance too. The difference between the reversal point 406 and tentative contact point 404 is calculated. The positions shown in Figure 12A purely illustrative and are nonlimiting. If the difference is lower than a preset threshold, we know this is not a typical finger. If the difference is above the threshold we declare it is a finger and the difference between the two is a measure of the stretching or tenting as discussed in copending U.S. Patent Application Attorney Docket No. 38187-2551US or Attorney Docket No. 38187-2677.

In one embodiment, the above rules result in many output codes from the contact point algorithm. They are summarized below.

1. Valid contact point detected (outputs contact point measurement and reversal point)
- 5 2. Stop Contact Search Point exceeded. No contact point detected because there was no slowdown within the Contact Search range (Start Contact Search Point to Stop Contact Search Point).
3. Start Contact Search Point error. The contact point (slowdown) was detected too close to the Start Contact Search Point such that the slowdown might have
10 already started during the establishment of the base speed.
4. Stall – A stall is an error that results from a slowdown detected, but no reversal (described above).
5. Contact Hard Surface – this error results from a the difference between the reversal and tentative contact point being is lower than a preset threshold. This
15 indicates the object hit did not deform, so we know this is not a typical finger.

The difference between the threshold value and the actual measured difference between the reversal point 406 and the tentative contact point 404 may be used to adjust the desired penetration depth. For example, if the distance between points 406 and 404 is greater than a threshold value, then this tissue exhibits more tenting than the standard
20 tissue model. The desired penetration depth may then be increased to account for the extra tenting. On the other hand, if it turns out that the distance between points 406 and 404 is less than the threshold, then this tissue exhibits less tenting. The desired penetration depth may then be reduced, by a proportional amount in one embodiment, since the tissue has less tenting to account for.

25 After the skin or other tissue relaxes, the difference between the reversal position 406 and the initial position 404 may be measured so that the amount of tenting T for this stick or lancing event is known. Now the actual penetration or depth in the skin or tissue may be calculated and a new target depth may be calculated by adding the variance of the actual depth from that of the threshold to the target depth to yield a new target depth
30 that now compensates for the amount of tenting. In one embodiment, the engine or penetrating member driver that actuates the penetrating member is reengaged to achieve the new target depth which includes the distance to compensate for tenting. This process

is relatively fast such as but not limited to under about 50 ms, so that it appears and feels like one operation to the user or patient. In another embodiment, at least one separate probe may be used to provide skin qualities. As a nonlimiting example as seen in Figure 12B, a separate probe 410 with mass and dimension substantially similar to that of the penetrating member 412 may be used to determine tissue quality. The probe 410 may be used to determine features and then the penetrating member 412 fired to create the tissue wound. In another embodiment, a coaxially mounted movable probe (slidable over the penetrating member) may be advanced to determine tissue quality.

In another aspect of the present invention, penetration depth may be controlled via speed and deceleration power modulation. Penetration depth of an electronically actuated penetrating member device is controlled by modulating the speed and the deceleration power. In other embodiments, the methodology was to accelerate the penetrating member to a constant speed and control depth by adjusting the point along the penetrating member trajectory where braking began. This current embodiment of the method takes advantage of the ability to modulate the amount of braking power applied as well as the ability to modulate penetrating member speed to control penetration depth. Penetrating member speed has also been studied and optimized for each depth setting. Varying the braking power provides a still further variable which may be adjusted to provide improved penetration depth control. It may also allow for more variety in velocity profiles used with actuating the penetrating member.

Referring to Figure 13, as a nonlimiting example, being able to increase the braking force allows a user to increase penetration velocity and maintain that velocity for a longer period of time in the tissue and then bring the penetrating member to a stop at the desired depth. In other embodiments as seen in Figure 14, it may be desirable to brake slowly over a greater distance and thus provide a soft stop. In a yet further embodiment as seen in Figure 15, the braking force may be modulated to be any combination of the above such as but not limited to an initial hard braking followed by a period of soft braking to bring the penetrating member to a controlled stop. It should be understood that any combination of the above hard and soft braking may be used. Variation in braking force also provides an additional variable during feedback control such that position of the penetrating member as it nears a desired depth may be braked with more force so that the penetrating member stops at the desired depth. It should be understood

that the above may be used with an electronic lancing device as disclosed in U.S. Patent Application Attorney Docket No. 38187-2551US. The braking force control may be adapted for use with a processor. The braking force control may be used with a multiple penetrating member device such as that disclosed in U.S. Patent Application Attorney
5 Docket No. 38187-2657.

Referring now to Figure 16, a schematic representation of the reperfusion of skin after impact with a tent and hold motion profile is shown. This figure is not to scale, and does not describe depth. This is a top down schematic view onto the skin or tissue. Penetrating member strikes perpendicularly to the skin in area A. Blood is initially
10 forced out to an area D. Blood will quickly return from D to C as the skin settles after the shock of impact. Tent and hold allows blood reperfusion from C to B and is due to the delayed deformation of the skin tissue immediately around A, unloading the peripheral skin tissue vasculature. The vasculature also functions as a pressure system, forcing blood towards the penetrating member after a delay that is related to the force of
15 impact. This pressuring is one factor in increasing spontaneous blood generation.

Referring now to Figure 17, two components of retraction profile are shown: As a nonlimiting example, reference letter A shows a "hold-to-neutral" position or range - when skin-penetrating member interface migrates together, and the skin settles naturally after the impact force tents the tissue. Perfusion acts as three-dimensional function of the
20 pressure. Pressure distribution and perfusion is cone-shaped, as illustrated by the blue triangle below. Reference letter B shows neutral to exit position or range where the actuator retracts the penetrating member from the skin.

Referring now to Figure 18, a high resolution image of the penetrating member and skin interface is shown. Specifically, the figure shows a "hold-to-neutral" phase -
25 when skin-penetrating member interface migrate together.

Referring now to Figure 19, a high-resolution optical image of skin relaxation "Natural Settling" with skin relaxing unimpeded by penetrating member.

In some embodiment, a tent and hold profile 1 at 2.6 ms may be used. A tent and hold profile 1 at 6.6 ms is used in some embodiments. Primary visible skin buckling has
30 broadened, and proximal edge of the wound channel has slid up the penetrating member shaft. A tent and Hold profile 2 at 3.9 ms is shown. Other experiment parameters are held

constant. A tent and hold profile 2 at 6.6 ms is shown. The buckling is not as evident, but the sliding is more obvious.

Referring now to Figure 20, a Natural relaxation 4 seconds after the strike is shown. After a good initial spontaneous flow, the flow stalls.

5 Referring now to Figure 21, a Tent and Hold profile 2 at 4s is shown. The motion profile results in an extended period of high spontaneous flow. Module fills despite large offset of the skin relative to the collection channel.

Spontaneous blood yield can be achieved by a lancing motion profile that holds the penetrating member at maximum extension for a prolonged period of time. The
10 viscoelastic of the skin may allow for a momentary tissue deflection that would rebound immediately after the penetrating member was retracted. A tent and hold lancing profile counteracts this natural property of the skin. In one embodiment, the penetrating member driver can maintain an extended position for about 2-8ms, and then make a controlled retraction out of the finger. The skin will slide up the penetrating member
15 shaft as the collagen matrix in the reticular layer inelastically deforms. In this nonlimiting example, the penetrating member continues to cut, but only as a result of the relaxation of the surrounding tissue. This deformation during the hold happens radially as well as axially to the penetrating member shaft. With tissue compressed more evenly around the lanced area, the resulting wound maintains its shape longer before it collapses
20 into a thin line that would resist blood spontaneously rising to the surface. The wound shape may exhibit increased blood sufficiency by counteracting tissue rebound characteristics using the tent and hold profile.

In one embodiment, to achieve a "tent-and-hold" event, the penetrating member penetrates to the intended depth and then may maintain the position in the skin to prevent
25 or retard the relaxation of the tissue, which would naturally return at approximately 1 m/s. In one nonlimiting example, holding the penetrating member in the skin between about 2 to 100 milliseconds appears to be ideal to achieve spontaneous blood yield. Deeper lances will require more "hold" time. In one embodiment, hold may be achieved by removing the drive force from the penetrating member while letting the skin or tissue
30 relax and reposition the penetrating member. In other embodiments, hold may involve placing the penetrating member at a fixed depth and maintaining that depth for the desired period. Although not limited by the following, motion profiles for which the

hold time is longer than about 1 second may introduce a deleterious physical reaction from the patient or unnecessary pain. It may also use more power from the motor to maintain the position of the penetrating member for an extended period of time.

Some advantages of a "tent-and-hold" motion profile or trajectory waveform

5 include:

1. Integrity of the wound channel by decreasing the effect of distension in the wound channel. The viscoelasticity of the skin may allow for a momentary tissue deflection that would rebound immediately after the penetrating member was retracted. A tent and hold lancing profile may counteract this natural property of the skin. This
10 behavior can be directly observed when the penetrating member is held for greater than 200 microseconds. The skin will slide up the penetrating member shaft as the collagen matrix in the stratum reticulare layer inelastically deforms. The penetrating member continues to cut, but only as a result of the relaxation of the surrounding tissue. This
15 deformation during the hold happens radially as well as axially to the penetrating member shaft. With tissue compressed more evenly around the lanced area, the resulting wound maintains its shape longer before it collapses into a thin line, which may resist blood spontaneously rising to the surface.

2. A limited amount of pinching and subsequent binding of the venuoles (at deeper lancing depths) by surrounding tissue at the target depth. In one nonlimiting
20 example, a strike with the best yield would involve the larger venuoles at higher depths filling the channel with blood. As the blood moves with the retracting penetrating member up the channel, the inside of the channel is coated with blood, allowing the blood in smaller venuoles with higher pressures to overcome to use the advantage of the blood's natural surface tension to lower the pressure threshold that would prevent blood
25 spontaneously coming to the surface. The momentum that a well-executed tent and hold with an appropriate retraction rate would build in the lancing channel not only decreases the number of sticks or lancing events with no spontaneous blood, but decrease the number of spontaneous sticks that are spontaneous but would require milking of the finger to gather a sufficient sample. This increase in the yield/depth ratio would thereby
30 reduce pain/yield, as an optimal retraction speed profile would reduce the depth sufficient to gather a sufficient sample.

3. The force of the impact evacuates the blood from the area around the penetrating member channel. This lack of movement after the impact allows for reperfusion into the area of the strike before any significant movement occurs. If the pressure is too high in the tented tissue area, the blood may not return until the retraction is performed. However, the coherence and focus of the tissue reperfusion is greater with the device-controlled relaxation of the penetrating member.

Once the penetrating member holds a certain period of time, there are two components of the retraction profile that influences blood spontaneously reaching the surface of the skin. The held-to-neutral subcomponent, (which may be at a speed), which facilitates a focused and optimal reperfusion of the lanced area; and the neutral-to-exit subcomponent, which allows the penetrating member to perform at least one of the following:

- Travel without binding or damaging the wound channel.
- Prevent the channel from closing up abruptly, enabling blood to displace the penetrating member as it performs a controlled exit.

The power requirement to hold a penetrating member may vary. Variations may be due in part to type of drive device such as but not limited to solenoid or voice coil and the like. In another embodiment, the penetrating member may apply a force only great enough to slow the relaxation of the skin, but not to hold the relaxation of the skin. The relationship of the power to tent-and-hold, or damp-and-hold may be related to: the skin characteristics e.g. hydration, possibly stratum corneum thickness. The power used to retract the penetrating member from a given depth or given skin may be used to relate characteristics of the skin. The wound stabilization characteristics required to get the blood out, reorientation of collagen fibers to keep the channel patent, may depend on the velocity profile used.

Some of the various embodiments of motion profiles, velocity profiles, or velocity waveforms are shown in Figures 22A-22C. As a nonlimiting example, Figure 22A shows a velocity versus time chart for a tent and hold velocity profile. After the hold period 500 where sufficient force is applied to hold the penetrating member at the current depth in the tissue, in this embodiment, there is a withdrawal phase 502 where the penetrating member is backed out of the tissue at a velocity slower than the average

entry velocity. The portion 502 is for velocity on the withdrawal of the penetrating member from the tissue.

Referring now to Figure 22B, another embodiment of the velocity profile is shown. In this embodiment, the profile is characterized as a "tent and damped hold" where sufficient force is applied to the penetrating member to allow it to move retrograde, but at a velocity slower than that which it would move if no force were applied and the skin or tissue naturally relaxes. The damped hold over region 502 may occur at a controlled rate. After this damped hold, the penetrating member may be backed out of the skin at reduced velocity as indicated by 502.

Referring now to Figure 22C, yet another embodiment of a velocity waveform is shown. Figure 22C shows an embodiment where there is a hold period 500, after which the penetrating member is withdrawn using a stepped withdrawal. In one nonlimiting example, the steps occur so that the average withdrawal speed is less than the average penetrating member inbound speed. The stepped configuration may provide more time for collagen in the skin to form around the shaft of the penetrating member during each withdrawal motion so that the wound shape and patentness of the wound channel may be maintained more easily (temporarily) by the collagen. This allows body fluid to more easily follow the wound tract created by the penetrating member so that the fluid can reach the surface. The steps may be at various spacings such as but not limited to about 50ms per step, 75ms per step, 100ms per step, or other step times as desired.

Referring now to Figure 22D, a still further embodiment of the waveform is shown. Figure 22D shows a profile where the hold period 500 is of an extended time. This may allow the collagen to form about the penetrating member to help maintain the patentency of the wound channel. After a selectable amount of time, the penetrating member may be backed out of the skin as indicated by 512. The embodiment shown in Figure 22D has the pull out occurring at an average velocity greater than that of the average inbound penetrating member velocity. In one embodiment, the overall time that the penetrating member is in the tissue may be about 500 ms. In other embodiments, the overall time in tissue or skin may be about 450ms, 400ms, 350ms, 300ms, 250ms, 200ms, 150ms, 100ms, 75ms, 50ms, 25ms, 20ms, or 15ms. These number may be applicable to any of the velocity profiled disclosed herein or in the profiles shown in U.S. Patent Application Ser. No. 10/127,395 (Attorney Docket 38187-2551).

Figure 23 shows an embodiment where it should be understood the penetrating member velocity may be increased or decreased or maintained based on various decision points along the velocity trajectory. Further disclosure can be found in commonly assigned, copending U.S. Patent Application Ser. No. 10/420,535 (Attorney Docket No. 38187-2664) filed April 21, 2003, and fully incorporated herein by reference.

Referring now to Figure 24, a still further embodiment, a controller may also account for pressure from applying a front end of the body fluid sampling device to the skin or tissue. The effect of front end pressure and stretching are discussed in U.S. Patent No. 6,306,152 fully incorporated herein by reference. Stretching from the front end may influence the amount of tenting of the underlying tissue. In one embodiment, the front end 560 may have an aperture sized of about 4.5 mm. The aperture may be varied in size from annular ring, square, triangular, polygonal, hexagonal, or other shaped. In one embodiment, the front end 560 may be movable into the housing as seen in Figure 25. The front end 560, when depressed, may configured to only provide a selected amount of force, thus making the tenting quality of the skin more controllable. In other embodiments, a pressure transducer 562 may be coupled to the front end. The measurements from the pressure transducer 562 may be used by the controller 564 to adjust the tenting adjustment. Various adjustment amounts may be stored in a lookup table in the device. The pressure transducer 562 may also be used during calibration or measurement of the tenting T so that it will be recorded and adjusted for if later lancements with the device do not occur at the same pressure. The tenting amount T may be adjusted based on the pressure used during the original measurement and the amount being applied during the current lancing.

In a still further embodiment of the present invention, a method for accurate control of penetrating member depth will be discussed. Referring now to Figure 26, the invention claims that the true depths may be consistently obtained for a desired depth by lancing to the desired depth neglecting tenting. In one embodiment, after this first depth 530 is achieved, the drive is turned off and skin or other tissue is allowed to relax until it has a neutral or "un-tented" as shown in Figure 17 and per previously described in commonly assigned, copending U.S. Patent Application (Attorney Docket No. 38187-2551) filed April 19, 2002, and incorporated herein by reference. In Figure 14, this position is shown at position 532.

After the skin or other tissue relaxes, the difference between the deepest penetration to position 530 and the relaxed position 532 may be measured so that the amount of tenting T for this stick or lancing event is known. Now the actual penetration or depth in the skin or tissue may be calculated and a new target depth may be calculated by adding the tenting distance T to the target depth to yield a new target depth that now compensates for the amount of tenting (assuming the position 530 represented the desired depth of penetration into tissue. In one embodiment, the engine or penetrating member driver that actuates the penetrating member is reengaged to achieve the new target depth which includes the distance to compensate for tenting. This process is relatively fast such as but not limited to under about 50 ms, so that it appears and feels like one operation to the user or patient.

In other embodiments, once the tenting T is calculated, the tenting amount T may be used for subsequent lancing events. A penetrating member controller (not shown) may include or be coupled to memory that will store this tenting distance. Thus, subsequent lancing events may be configured to account for the tenting distance on the first inbound stroke and achieve a desired depth without necessarily using a true depth type penetration stroke on each lancing event. Thus the depth for penetrating member penetration will include a desired depth D and the tenting T. The calculation of tenting T may be initiated on a first lancing event by the user and on any subsequent lancing events as desired by the user for recalibration of tenting purposes. In still further embodiments, the tenting distance T may also be adjusted by a certain amount (such as but not limited to $\pm 1\%$, $\pm 2\%$, $\pm 3\%$, $\pm 4\%$, $\pm 5\%$, $\pm 6\%$, $\pm 7\%$, $\pm 8\%$, $\pm 9\%$, $\pm 10\%$, or more) based on the time of day and hydration pattern of the user or patient. A lookup table containing different tenting distances T may also be used to pick off the desired amount of tenting compensation based on a number of variables such as but not limited to: time of day, hydration, age of patient, or other patient information.

In some embodiments, the penetrating member on the inbound path penetrates into the tissue during the tenting measurement. In other embodiments, the penetrating member does not fully pierce the patient while gathering information of tenting distance.

Referring now to Figure 27 and 28, further embodiments of the present invention will now be described. These embodiments relate to modifications for the electronic drive mechanisms used with the present invention.

Solenoid Study

The objective of the solenoid study is to further understand its operation and to look for techniques to further enhance the force capability. The existing solenoid design results in a very non linear force profile, and in all changes we are looking to increase the overall force while improving the low points in the achievable force.

2.1.1 Disk Thickness

Several modeling runs were conducted to study the effect of increasing the thickness of the coil disks on the peak coil force. It is thought that the disks are in saturation at the inner diameter. Therefore increasing the thickness of the disk reduces the saturated diameter of the disk, concentrating the coil flux closer to the centre. This increases the available force when the slug is away from the disk but has little effect as the slug approaches the disk, resulting in little change to the low points in the force profile.

For other embodiments, additional work was done looking at tapered disks and other methods of thickening the disk without compromising coil volume. From this it was seen that the slug force is greatly reduced once the front face of the slug enters the disk. In one embodiment, a 0.3mm disk offers a good compromise between force and available coil volume without introducing flat (near zero force) points in a single coil energization curve.

2.1.2 Slug Dimensions

Several modeling runs were conducted to study the effect of varying the length and the inner and outer diameter of the slug on the peak coil force. In one embodiment, it was found that increasing the slug length was beneficial, so this was set at 4.87mm. There was also a significant and increasing relationship between outer diameter and peak force – it was decided to settle on a slug OD of 3.6mm in one embodiment. Over the range modeled, the effect of varying inner diameter was negligible, although slug mass was decreased.

The above table shows the effects of increasing the slug dimensions. The latter results from ID of 2 – 3mm are extrapolated from the results and show the most promising increase in force available. This force is shown in terms of the Acceleration factor, i.e. the ability of the solenoid to accelerate the Total Carriage Mass.

From these results we estimate that some controlling factors are the Slug End Area, relating to the area available for the flux lines to act upon and the acceleration factor. Assuming this is correct, in one embodiment, the desired dimensions for increased force are an OD of 3.6mm with an ID of between 2.6 and 2.8mm to match to the existing end area at an OD of 2.4mm

2.2 Split Slug

In one embodiment, the concept behind the split slug was to even out the force profile over the whole slug throw by firing two coils simultaneously, whilst ensuring that when one slug is in an active force region, the other is producing no force and vice versa. This route was particularly interesting as a way of linearising the force profile.

2.2.1 Split Slug - testing

In order to test the theoretical force curves, two pairs of metal slugs were made. One set was 2.53mm long and the other set 2.33mm. These sets were slid onto the end of metal wire with a spacer between the pairs to set the coil pitch at 3.28mm. This spacer dimension was based on the simulation data suggesting an optimum gap of 1.41 x coil pitch.

In one embodiment, a static test was performed - the force applied to the slug assembly by a single active coil at several fixed positions through the coil was measured. The end of the slug assembly was attached to a 600g load cell, and the coil was attached to a track that allowed the slug to be accurately positioned within the solenoid. A 15.6A constant current supply was applied to the coil for a duration that allowed the force applied to load cell to stabilize (35ms).

In one embodiment, starting with the back edge of the slug flat with the back edge of the solenoid "zero position", the slug was moved in 0.2mm increments through the solenoid; this allowed a force profile for the slug and solenoid to be recorded. Profiles were recorded for the 2.53mm pair of slugs, 2.33mm pair of slugs, and individual slugs at 2.53mm and 2.33mm.

In one embodiment, the static test force profiles for the split slugs can be compared to the results from a previous static test done on a full-length single slug as can be seen in Figure 28 which illustrates a split slug force profile. A full length 4.87mm slug generated 1.5N. The peak force for a 2.33mm slug was 0.92N. The peak force for a 2.53mm slug was 0.96N. The force on a split slug completely changed direction in

0.8mm from peak to trough. At the overlap of coil influence a maximum of less than 0.1N could be applied to the slug in either direction.

In some embodiments, by going to a split slug design, the drop in the overall peak force available was significant. The peaks and troughs in force are still large enough to
5 make it difficult to assume an effective linear control strategy. The large drop in force is likely due to plate saturation. The plates closest to the active coil saturate when turned on and the magnetic field extends to include the next set of plates, the smaller slugs are too small to make effective use of the force provided from these more distant plates.

2.3 Electrical Improvements

10 In one embodiment, the main aspect of the electrical system is the power supply and the FET drive. This system takes up considerable space as large capacitors are used to supply sufficient energy to the solenoid.

2.3.1 High Voltage Drive

Referring now to Figure 29, in one embodiment, the current power supply is
15 based around a 15.5V boost converter using 20V rated FETs and 16V rated electrolytic capacitors. By increasing the voltage which the boost converter supplies, the energy stored in the capacitors is significantly improved in accordance with the equation:
Energy = $\frac{1}{2}CV^2$. A higher voltage system would use different capacitors and transistors, but the capacitance used to achieve equivalent energy storage would be greatly reduced
20 and consequently the size of the capacitors.

Approach

In one embodiment, the next common voltage range of capacitors above 16V is 35V and therefore it was decided to test a 30V system using an equivalent energy capacity to 13600 μ F at 15.5V which is approx. 3300 μ F at 30V. In addition the FETs
25 tested were dual FET packages rated 55V – Part No. IRF7341

In one embodiment, a test were devised to give a comparison of available force between the 15.5V and 30V systems. Static tests could not be used to obtain a force profile for the higher voltage system, as a steady supply that could provide the desired energy to the system could not be acquired. A dynamic test was seen as the best
30 alternative and most accurate measure of performance for a 30V system.

In one embodiment, the coil was placed vertically so that the slug could be fired upwards to reduce the effects of friction in the system. The slug assembly's weight was

adjusted so that it was exactly 1g, this enabled the slug to be fired at a slower speeds which reduced encoder noise. A logic analyser running at 100Mhz was attached to the output of the optical encoder in order to log the time at which encoder edge inputs occurred. The slug was moved so that its back edge was flat with the rear of the solenoid
5 "zero position" (see Figure 30).

First - the central coil was pulsed at 100 μ s to 1500 μ s at 100 μ s intervals to check that the acceleration profile was independent of pulse length.

Second - the starting position for the slug was raised through the coil at 0.5mm intervals to 2.5mm and the central coil was fired for 1200 μ s at each of these positions.

10 Finally - in one embodiment, the extra weight on the slug assembly was removed (making the weight 0.28g), this was in order to get a speed comparison to previous tests performed at 15.5V. The slug was moved so that its back edge was flat with the rear of the solenoid and the central coil was fired for 1200 μ s.

During all of the tests at 30V, the current that could be drawn to charge the
15 capacitors was limited to 0.1A (0.2A was allowed for all previous experiments at 15.5V). For a given starting point all pulses accelerated the slug along the same acceleration profile. Figure 31 shows the speed traces for different pulse lengths in μ Seconds.

In one embodiment, by incrementing the start position of the slug towards the
20 active coil, the acceleration of the slug appears to increase. The noise in the system means accurate measurement of the discrepancies between the acceleration is virtually impossible. However, it was possible to calculate the average force over a broad section of the force profile by using the maximum speed achieved and the associated time to obtain an average acceleration value. The mass was then divided in to obtain the force.
25 The noisy position data was not significant over large displacements and therefore an average force within those displacements could be calculated using the data shown in Figure 31.

In one embodiment, by removing the extra weight from the slug and firing it
from the zero position with the middle coil the slug reached a maximum speed of
30 15.5m/s. The energy in the 3300 μ F capacitor with a limited 0.1A supply was sufficient to accelerate the slug assembly to 15.5m/s and then decelerate the slug to a complete stop without any deterioration in the acceleration profile. The lower voltage system showed some deterioration in acceleration during the braking section of an equivalent test.

The acceleration profile is independent of the pulse length. The force on the slug has been increased significantly with no detrimental effects observed. This has been done with the use of smaller capacitors as highlighted by the lower mass experiments. The average force produced by the 30V system was 6.6N compared to an average force of 3.7N for the 15.5V system. The clear advantages of this approach are:

- Smaller capacitors
 - Higher forces, giving faster acceleration / deceleration, higher speeds and increased ability to pull out, push in static / standing forces
 - Increased magnetic field influence (potentially fewer coils used)
- 10 2.3.2 Recommended next steps – Electronics optimisation
- Change the 15.5V PSU rail to a 30V rail and change the capacitor size to 3300mf.

15 A possible further avenue of exploration is to measure PSU energy use during the complete firing cycle and use these results to set the absolute minimum size of the capacitor.

- Redesign of the boost converter using a transformer to optimise the efficiency of the converter at this higher voltage.

A new rig is currently being designed in order to obtain the higher positional resolution needed to gain an accurate force profile.

20 3 Control System Development

3.1 Objective

The launcher system technical objectives include:

- accelerating to a speed of at least 4m/s.
 - achieving a positional accuracy on stopping of +/- 0.05mm at any set
- 25 depth between 0.5 and 3.5mm
- retracting from the skin under control at slow speed

The objectives of this part of the work were to create a model to test control algorithms for the system and to create and test the models over a wide range of conditions.

30 3.2 Approach

3.2.1 Modelling environment

One embodiment of the launcher system was modelled in Matlab / Simulink. Matlab is a numerical modelling environment able to manipulate and compute mathematical models based on matrices. It is both command-line and script driven. Simulink is an extension to Matlab. It is a graphical environment which allows dynamic system modelling using the notation and conventions of control system block diagram models. Models are defined, initialised and then a simulation of their dynamic behaviour is run over a specified time sequence. Using Matlab scripts, multiple model runs were executed enabling fast analysis of model sensitivity to variables.

3.2.2 Model composition

The Simulink model created is in two parts:

the controller, which runs the control system software. This handles all phases of the launch and retract cycle

the test shell, which is a model of selected physical features of the launcher and the electronic input / output system, essential for testing the controller.

Referring now to Figure 33, one embodiment of a launcher system model is shown. The approach was modular and iterative – the different system functions of sampling, controlling speed, timing the coil current were split so that each could be improved in isolation. The components of the model are shown in Figure 7. During the development of the model, some further decisions on implementation were taken – chiefly on the PWM / Coil drive system.

The controller has two parts – the state controller and the dynamics controller. The state controller is designed to execute the whole launch cycle – acceleration, braking, then slow and fast retraction. The dynamics controller deals with adjustments to the coils to achieve control of the carriage.

The test shell and the controller were both initialised from a Matlab script which sets up global constants for the current simulation run. During the run, simulation data is output to Matlab where it can be stored and later analysed. The main focus of work during development was on achieving a tight positional accuracy on insertion.

3.2.3 Realism

In operation, the launcher electronic system has many interactions but the system elements with the biggest impact on the control algorithm are:

the encoder

the technique used to drive the coils
the coils themselves.

The some characteristics of the launcher system which were used in the model are tabulated here:

Skin		Coil	
Skin offset from rest position	4mm (fixed) ¹	Coil force gain	3N peak
Skin force gain	114 N/m gives 0.4N @3.5mm	Coil offset from zero position	3.5mm
noise s.d.	3.5%	Coil pitch	2.33mm
depth setting	0 - 3.5mm in 0.1mm steps		
		PWM	
Encoder		PWM period	50µs
Number of channels:	2	resolution	8 bit
Positional resolution:	42.32µm	throttle setting	50%
Standard deviation of positional measurement:	+/- 1µm		
Carriage			
Mass	2.98g		

5

3.2.4 Implementability

In order to be fit to implement in a low-end microcontroller, the control algorithm must be constructed from a limited set of mathematical operations and run at a speed, which will fit within its computational capability. In outline, the mathematical functions that will be used are:

10

- 16-bit fixed point add /subtract
- 16-bit fixed point multiply/divide
- Look up table.

During this phase of testing, full 32-bit floating-point arithmetic was used.

15

3.2.5 Force Control - Pulse width modulation and coil firing

To achieve control over the level of coil force developed, the model contains a PWM module. This pulses current to the coils in time slots of 50ms. Within this period,

the time resolution was 8 bits, giving 256 selectable firing durations. Averaged over the PWM period, this gives direct control of the average force.

Referring now to Figure 34, a 5 Coils Force Profile is shown.

A simple rule was needed to decide which coil to fire during the cycle. Static force tests on the solenoids provided a force – distance profile (see Figure 34). The controller was programmed to use the following simple switching rule:

In this embodiment, at all positions, select the coil that will generate the greatest force.

This rule was encoded in 2 tables of 4-elements containing the switchover points for the 5coils for insertion and retraction. Because of the modular approach, the coil was treated as an instantly responding actuator. This means that other combinations of coil switching e.g. 2 coils at once can be employed within this module without affecting the architecture of the system.

3.3 Control Techniques studied

The physical system (plant) under control is a moving mass system with almost instantaneous direct control of the applied force. The only plant information is the position of the carriage. Two techniques were studied to achieve positional control.

3.3.1 Acceleration-based

In one embodiment, acceleration was measured by differentiating the position signal twice, and averaging this signal over the PWM period. This smoothed value was used as an input to a simple proportional controller, employing no integral or derivative action – see Figure 35. The output was fed to the PWM module as a time demand – which is translated to a force as described above. The results of this processing were favourable.

As seen in Figure 35, a portion of the control algorithm - Acceleration control, is shown.

In this algorithm, the throttle is a logic signal, and the PWM demand is evaluated when triggered every PWM period (50ms). The PWM demand is a smoothed version of the acceleration error as the sum takes inputs from both the current and previous PWM periods. There are three model parameters – the constant PWM value and the two gain Figures.

The rationale was to create a servo system which would respond quickly by adjusting the coil force in response to any given acceleration demand. If this were possible, velocity and position could be controlled accurately as a result. The acceleration demands are set according to a state controller which runs the launch and retract cycle and is common to all the models discussed here.

A side effect of measuring the acceleration is a real-time measurement of the coil force during the previous PWM period. The acceleration controller's reason for being and its main error input is the variation in coil force caused by the solenoid.

In one embodiment, a forward-looking condition was then used to initiate braking. The results of testing this algorithm can be seen in Figure 36 and further discussed in Figure 44. A sign of the correct operation of this algorithm is the variation in PWM duty cycle in sympathy to variation in the coil force, which can be seen. One of the initial findings about this controller was that it is sensitive to gain values that are coil-dependent. It also failed to use the maximum force regions of the coils to full advantage, because it was targeting an acceleration value which was achievable even in a low coil force region. This was quite unsatisfactory as a hard braking method.

Following initial testing of this algorithm it was decided to focus on the energy control algorithm. The acceleration control algorithm was not tested with later model enhancements.

3.3.2 Energy based

In outline, the 2nd technique of controlling to achieve positional accuracy was based on equating the energy available to stop the carriage in the remaining distance with the kinetic energy, which it has at the skin entry point.

The approach was to send the carriage on a braking profile that uses a fixed fraction (the energy set point) of the total work available from the coils. In practice, this is achieved by setting the PWM value at a constant fraction of 100% duty. Because the coil force varies with carriage position, the effect of this on the carriage is to decelerate it on an uneven speed profile. The speed profile can be calculated from a coil force map, which is obtained experimentally, is stored, and forms part of the control algorithm.

Three important quantities are now introduced. These are shown on Figure 37:

The energy / speed set profile. For a given energy set point, it is known what the coil force, and therefore the work done by the coil, will be, throughout braking.

The work done on the carriage by the skin is also known. By adding these together, the total work done on the carriage is calculated. Therefore, the idealized profile of carriage kinetic energy against distance can be calculated for the braking phase. This is used as the set point profile for control. Assuming there are no errors in the prediction of force on the carriage, this is the profile the carriage will follow when braked at the energy set-point with no intervention from the controller.

The total work available to brake the carriage from the skin + the coils. This is all the work that can be done on the carriage as it travels to the desired skin depth. It is also the profile which the carriage would follow under the action of 100% coil braking and skin force. This defines the control envelope -- if the carriage kinetic energy departs outside this curve, it is certain to overshoot the stopping point.

The difference between the energy set-point and the total work available is the energy margin. This spare work is used to correct for errors between the actual speed and the set speed.

In principle, to obtain a high level of braking, a small level of energy margin is used. To compensate for a large level of errors, a larger energy margin is used. The trade-off between the two can be reduced by improving the performance of the in-built control system. A diagram of the energy control algorithm is shown in Figure 38.

Referring now to Figure 38, another portion of the control algorithm - energy control, will now be described. In this embodiment, this algorithm is continuously evaluated. A lookup table is used to read the current Figure for "braking work". The "skin work" is pre-calculated by a formula based on skin depth and is also stored in a lookup table. The energy set profile is calculated from the sum of skin work and braking work (scaled). The error (energy error) produced by subtracting this from the carriage kinetic energy is then scaled by a gain and modifies the fixed PWM value.

The main error source which the controller acts on is the error between the predicted force - distance relationship of the skin and its actual value, together with the associated variation (skin noise). This is therefore one of the main testing usements.

Implementation - data storage

In order to use the concept of a dynamic energy set profile as an input to the controller, the carriage force profile needs to be stored. This is more sophisticated and

data intensive than acceleration control. Even so, 0.1mm resolution can be achieved to 4.0mm depth with only 40 stored values.

Following initial testing, the performance of the energy-based control strategy was promising. In some embodiments, the positional error on stopping was between –
5 0.5mm and -0.15mm.

After some testing of different methods for calculating the energy set profile, it was decided to use the following formula to calculate it:

1. Take the estimated work available from the skin from entry to stopping point
 - 10 2. Add in the work available from coil braking, scaled for the energy set point
- 3.4 Sensitivity Study

The control approach described above is data-intensive. There are several parameters, which affect the performance of the model to varying degrees. An
15 illustration of the variables within each module and the extent to which they are under control is shown in Figure 39. During the course of this study, it was desired to test the effect of variation in the important factors below to ascertain the level to which they affect system performance. Fortunately, the models can be run repeatedly to investigate these variables over a range of values. During the sensitivity testing, roughly 100
20 simulation runs with different parameters have been completed.

Referring now to Figure 39, the nature of the module variables will now be described. The effect of each of the parameters highlighted in bold above on stopping accuracy has been checked. It was decided that the level of launcher friction was so low as to be insignificant in comparison to the other active forces (coil and skin force) and
25 that therefore this was not essential to the model.

Encoder noise

In one embodiment, positional noise from the encoder affects velocity and acceleration measurements. The effect was characterised experimentally. From experimental data, the standard deviation of this noise was found to be +/-1mm. The
30 noise component of this signal was added into the model as an error signal. The effect on the velocity measurement can be seen in Figure 1 - a noise signal is created. Throughout modelling, a value of 1mm was selected. The limit on encoder noise beyond

which positional control was significantly degraded was 2mm. A more complete graph of this effect is shown in Figure 40.

Coil force measurement

In one embodiment, the controller braking profile is based on measurements of the coil force conducted in a static force test. The effect of variations in these forces was studied and the result is shown in Figure 40. For the tests shown in this Figure, the predicted coil peak force was 4N. The actual coil force was varied from 2 to 6N. As can be seen, the effect of underestimating coil force is much less critical than that of overestimating it. The stopping accuracy was generally within 0.1mm of the desired stopping point, except at low levels of actual coil force. In that case, overshooting was more serious, at up to 0.3mm at 3mm set depth.

Skin Entry Speed

In one embodiment, the skin entry speed was targeted so that during braking, the carriage kinetic energy would converge with and run down the pre-programmed profile. Because of the fact that increased skin penetration depth brings more energy available from the coils to stop, this naturally means that the deeper the stopping point, the faster the entry speed.

This way of targeting skin entry speed is not optimised for flight time, as the carriage could be driven faster in the early part of its flight, then braked before entering the skin. This refinement is particularly relevant for shallower depths but was not seen as useful to the set depth accuracy problem. Either side of its velocity set point, the braking controller has a "capture window" within which it can bring and keep the velocity under control during braking. Outside of this window the carriage either ends up overshooting, because the energy margin has been used up, or the carriage has insufficient momentum to enable it to reach its desired position and it stops short.

A refinement that could be tested to deal with either of these eventualities was asymmetric gain.

Coil Usage

During the full insertion and retraction cycle, coil 0 alone is used for braking and acceleration. Because this aspect of the model is fully parametric, the force profile for predicted coils and actual coils can be quickly modified and retested when other coil layouts are tried.

Sensitivity to errors in skin force prediction

In one embodiment, the algorithm improves positional stopping performance by including a prediction of skin force and hence energy. This estimate was obtained from experimental data. By including this prediction, it introduces sensitivity to that data.

5 Testing was conducted to explore the effects of errors of factors $\times 2$ and $\times \frac{1}{2}$ in the average skin force for comparison with nominal data. The results are shown in Figures 43 and 44 below show these three skin force gain scenarios.

The graph in Figure 42 is encouraging – it shows the overall performance of the algorithm over a range of set depths and skin force gains.

10 At deeper set depths, the sensitivity of the positional accuracy to errors in skin force is greater than at lower depths. This is to be expected intuitively, as the work done by the skin increases as a quadratic function of distance.

At lower set depths, the entry speed was simply too low to enable the algorithm to work effectively. This needs more complete testing and probably a different approach for shallow entry. It should be borne in mind that in this testing, the energy control
15 concept was only implemented within the skin and not in free space.

One of the best ways counteract errors in skin force prediction is to make the total possible error small in relation to the coil force, which can be controlled. This is done by increasing the coil force. The effect of this can be seen in the earlier Figure 41 and also
20 in Figure 43. The three traces show simulations conducted at the same coil force and stopping error was greater when skin force was underestimated (red trace).

In general, the control algorithm involves using a pre-programmed speed profile at a fixed coil throttle setting and using what coil force is left to cancel out errors arising from skin and other forces.

25 Studies of sensitivity to errors in predicted skin force, encoder noise and to variation in coil force have been conducted and the effects recorded.

Using a higher force in relation to skin force enables more precise positioning to be achieved.

Using a peak coil force of 3N, insertion positioning to within ± 0.1 mm
30 can be achieved over a range of set depths from 1 to 3.5mm and over a range of skin – force curves. At lower coil forces, positioning accuracy is degraded.

Control system Development

Control algorithm - Test the idea of using an asymmetric gain on the energy error signal during braking. Include a model of the launcher friction. Change the method of calculating the energy set profile for shallow skin entry.

Implementation - Construct a prototype system using MatLab RTW to produce real time code to run on MatLab XPC real time PC system. This will allow further testing and development of the control algorithm on the real hardware and skin.

Implementation - Model the system using only 16-bit arithmetic and change the energy-based algorithm to a velocity-based one to maintain signal precision.

Implementation - Modify the algorithm to operate at the (much slower) PWM frequency, rather than in near real-time.

Testing - Test the revised algorithms using a similar test suite as described here.

Experimental / mechanical data - Update the coil force graphs and dimensional parameters for the latest mechanical layout

4 Position Sensors - LVDT

In one embodiment, a linear variable differential transformer is an alternative to the optical encoder as a means of position and speed sensing. In a successful realisation, the chief advantages over the optical encoder are:

- a higher linear resolution
- a smaller package size and a shape which is easier to integrate
- The ability to provide position updates to the microcontroller on request, rather than having an interrupt-driven system, which aids software design.

Lower cost

The simple basic design of the LVDT is versatile and offers a wide scope for customisation. LVDTs also offer fast dynamic response, they can make measurements at up to 1/10 of the driving frequency on the primary winding. For this application, that translates into an ability to sense movement at >50m/s. Although widely used in industrial equipment, they are rarely found in low cost consumer items. The objective for this study is to prototype a design and to find an optimal solution for the launcher.

4.1 Design Issues

Operating frequency Needs to provide positional updates at a rate close to that of the current sensor (4-5ms). May be possible to go to 10ms. Assuming an ADC.

system is used where the ADC can sample successive peaks, then the driving sine wave source frequency is in the range 100kHz to 250kHz. For this application it should be able to sense movement at >50m/s. The maximum frequency of the coil drive is limited by air coupling

5 Resolution To match the encoder resolution uses 1024 positional steps –
10bits

 Moving weight Must not adversely affect the performance of the solenoid
– carriage system.

 Packaging Length <30mm, diameter < 8mm

10 System BOM cost, including electronics <\$3.00

 Throw distance 8mm

 Table 2: Outline LVDT specification

 The LVDT electronics is comprised of the following elements:

 • Drive circuit. For low component count and design simplicity, it makes
15 sense to control the LVDT drive directly from the microcontroller.

 • Sense / sample circuit. Must provide gain and offset zeroing and also the
ability to hold the signal for the ADC.

 • ADC. Must provide sufficient conversion speed to satisfy the frequency
usement.

20 4.2 Coil parameters

 4.2.1 Coil disposition

 The layout of the coils in commercial LVDT products is such that they may be
used in a single ended mode, ie a moving soft metal slug enters from one end only. A
simpler design could be a centre primary with two secondary windings. In this case the
25 slug length is the primary length + a single secondary length.

 By careful design of the numbers of turns and dimensions of the primary and
secondary some gain can be achieved within the LVDT to improve the signal to noise
ratio of the secondary signals.

 4.2.2 Single coil

30 LVDTs traditionally have two coils, each of which produces an output which is
linearly proportional to the position of the slug. When subtracted, the two voltages
cancel at a zero position. This removes the effect of air coupling. If the sensing /

sampling circuit can be designed such that the air offset is zeroed then a single secondary coil can be used. This would produce significant packaging benefits.

4.2.3 Recommended next steps – LVDT

Purchase a commercial LVDT and develop suitable drive circuitry for interface to a microcontroller system.

Referring now to Figure 44, a predictive braking algorithm is shown. By modeling the penetrating member driver and the tissue to be penetrated, a “road map” of short is provided to determine when the braking should be applied to achieve a desired depth. Feedforward systems are described herein and are used in combination with a lancing device such as that described in commonly assigned copending U.S. Patent Application Ser. No. 10/127,395 (Attorney Docket 38187-2551 and 38187-2606). Feedback is used in combination with feedforward. In this embodiment, feedforward may be used for braking of the penetrating member or more precisely, the slug driving the penetrating member. The feed forward algorithm may be stored in a processor used to control the penetrating member driver. Figure 44 shows in detail how the planned velocity is used to determine how to reach a desired depth. In one embodiment, the entire inbound path is traveled in under 10ms, which is faster than most humans can see. Hence the need for feedforward to provide a planned velocity so that the accurate depth can be reached without lag and/or instability that may be associated with a feedback only system.

As each device is manufactured, each driver may be modeled during manufacturing to adjust the model for each driver. In other embodiments, a standard model may be used.

While the invention has been described and illustrated with reference to certain particular embodiments thereof, those skilled in the art will appreciate that various adaptations, changes, modifications, substitutions, deletions, or additions of procedures and protocols may be made without departing from the spirit and scope of the invention. For example, with any of the above embodiments, the location of the penetrating member drive device may be varied, relative to the penetrating members or the cartridge. With any of the above embodiments, the penetrating member tips may be uncovered during actuation (i.e. penetrating members do not pierce the penetrating member enclosure or protective foil during launch). With any of the above embodiments, the

penetrating members may be a bare penetrating member during launch. With any of the above embodiments, the penetrating members may be bare penetrating members prior to launch as this may allow for significantly tighter densities of penetrating members. In some embodiments, the penetrating members may be bent, curved, textured, shaped, or otherwise treated at a proximal end or area to facilitate handling by an actuator. The penetrating member may be configured to have a notch or groove to facilitate coupling to a gripper. The notch or groove may be formed along an elongate portion of the penetrating member. With any of the above embodiments, the cavity may be on the bottom or the top of the cartridge, with the gripper on the other side. In some embodiments, analyte detecting members may be printed on the top, bottom, or side of the cavities. The front end of the cartridge maybe in contact with a user during lancing. The same driver may be used for advancing and retraction of the penetrating member. The penetrating member may have a diameters and length suitable for obtaining the blood volumes described herein. The penetrating member driver may also be in substantially the same plane as the cartridge. The driver may use a through hole or other opening to engage a proximal end of a penetrating member to actuate the penetrating member along a path into and out of the tissue.

In one embodiment of the present invention, an LVDT position sensor module will now be described. As a nonlimiting example, the LVDT, incorporating the bobbin 710, primary coil, core and secondary coils. Figures 45 and 46 show one embodiment of a bobbin 710 according to the present invention. The bobbin 710 may include a coil separator 712. Secondary coils may be wound over regions 714 and 716. The hub portion 718 may be removed after manufacturing to further decrease the size of the bobbin 710. The diameter of the bobbin 710 may be varied. The length is determined by the through distance and a slight variance for magnetic effects. In one embodiment, the coils are .6 mm wire. The layers determines the number of coils. The fewer turns used, the less field you get. The present embodiment may have four layers for the secondary and two for the primary coil. It should be understood that other combinations of layers such as two and one may also be used. It is seen that a physical wall 712 is used to separate the coils (not shown). This provides for simplified manufacturing. The coils may be wound in a uniform manner, in one embodiment. A processor may be used to interpolate the nonlinear output from the coils. Each processor may be calibrated to the

output to linearize it. In further embodiments, a wall 712 may be removable after the coils are wound. In still further embodiments, a clamp may be placed on the bobbin during winding and may be removed after the coils are wound.

The entire system may also include coil drive electronics, signal conditioning and microcontroller hardware, and firmware to control the microcontroller modules and process the incoming signal.

One reason for considering the LVDT as a position sensor is because of its advantages over an optical encoder. These break down into advantages for the product (the potential for lower cost manufacture and improved packaging), as well as functional advantages for the control system: (high speed, high accuracy on-demand position measurement).

Desired Features

To replace a linear encoder as a position and speed sensor, the LVDT module desire to have at least one of the following: Size – as small as possible; stability – the encoder module is stable with temperature, so the LVDT should be too; range / resolution - 20m across the measurement range of 8mm; response time / update frequency – 5s / 200kHz; and/or moving mass – as low as possible, to limit the effect on carriage ballistics.

Referring now to Figure 46, a generic system schematic showing the modules and their relationships is shown. In one embodiment, for its operation, the module relies in part on the timing relationship between the signal which is used to drive the LVDT primary coil, sourced in this embodiment from a PWM module, and the sampling time of a 10-bit ADC. As a nonlimiting example, these may both be integral blocks on board a 16-bit microcontroller. These blocks operate in synchronism, which reduces the need for external componentry. The phase delay is set by internal microcontroller settings and by parameters of the external circuit. ADC sampling time is synchronized with the input signal in the present embodiment.

Figure 48 shows the timing of the signals of interest. Figure 49 shows one embodiment of the drive electronics which implement the coil drive and signal conditioning. During initial testing, a working frequency for the primary drive circuit was chosen in one embodiment which enables the ADC to make one sample for every cycle of the LVDT drive signal. By the adjustment of the phase delay, the ADC can be

made to sample at the peak of the secondary coil cycle, thereby making the best use of the available positional resolution. As seen in Figure 48, the system may use a square wave input 750. A resonant circuit may be used to convert this square wave into a sinusoidal waveform to drive the primary coil. In this embodiment, sampling by the
5 ADC is related to the square wave input 750. It should be understood that a sine wave generator may also be used in some embodiments. A certain delay may be used so that the sampling occurs at the optimal point 752 (as seen in Figure 48).

By synchronizing the timing of the ADC samples to the drive signal and by using the internal sample and hold circuit, the design of this embodiment avoids the need to
10 include external rectification or hold circuitry.

LVDT Primary coil drive

The LVDT desires a sine wave to drive the primary coil: this is achieved by exciting a parallel resonant LC circuit with a square wave input (TIOCA1 – Vdrive signal). This is then amplified (U1C) to create a lower impedance source for the primary
15 coil. The LC circuit is adjusted to resonate at the module operating frequency and R3 is used to limit the output amplitude. R4 compensates for the primary coil DC impedance to prevent output clipping on U1C.

Coupling and secondary coil signal conditioning

The voltage ratio of the LVDT is a function of the turns ratio and the geometry of the coils. This is chosen, alongside all the gains in the signal path, to preserve SNR. The
20 secondary coil voltage is fed through a standard high gain differential amplifier (U1D) before being fed into the ADC. The choice of resistor values for U1D is driven by the need to obtain maximum gain without loading the LVDT secondary coil or the op-amp excessively. The entire LVDT drive circuit is referenced to a stabilised mid-rail voltage
25 to use the op-amps most effectively.

ADC conversion and signal processing

The timing of the ADC sampling and conversion process is shown at the bottom of Figure 4. The ADC is triggered by the TPU, which also supplies the PWM signal. It samples near the peak of the negative going half-cycle. The ADC voltage reference pin,
30 Vref, is set-up so that the ADC gives its full 10-bit resolution over the anticipated voltage swing of the amplified LVDT secondary signal at the sampling time. With the LVDT optimally set up, this is the whole PSU rail voltage. The output from the ADC as

the LVDT core was moved over its travel can be seen in Figure 50. A look-up table of 13 calibration values was used to encode the ADC counts over a range from 7.50 to 14.00mm. The sampling of the ADC may be increased from 10ms to 7ms (40kHz) depending on the microcontroller used.

5 Module Components

Drive Electronics – Op-Amp circuit

In one embodiment, the rail-to-rail op-amp chosen for the prototype circuit was the National LM824. From the table below, it was chosen because it is a low cost device, it has a 3.3V capability, a respectable gain-bandwidth product of 5MHz acceptable input offset voltage and output drive capability, whilst offering 4 channels of gain.

10 In the three instances in which it is used, there are differing requirements. In each one current drive capability and gain bandwidth product are the most important

Mid-rail supply – U1B, Coil Drive – U1C

In both these instances, the closed loop gain is 1, so the greatest requirement is for output drive capability. When testing the LVDT #0, the 75R resistor was necessary to prevent output clipping. With LVDTs #1-#4, this was reduced to 27R.

Secondary Gain – U1D

The op-amp was set-up to give a closed-loop gain of 1 at 100kHz which is well within its gain – bandwidth capability. This op-amp will cope with 200kHz testing, and it may be possible to specify an op-amp with a lower GBW product, and reduce cost further.

Microcontroller hardware – ADC / TPU

The LVDT circuit was prototyped on a Hitachi H8S2318, running at 20MHz. The operating frequency of the circuit was 100kHz. One of the limiting factors on this is the ADC conversion time, which was measured at 5.8s. This conversion rate is slower than the ADC on the proposed H8S3694 microcontroller, which is specified at 3.5s.

Module performance

In one embodiment, two designs of LVDT were tested. LVDT #0 was a simple design with three similar coils adjacent to each other. LVDTs #1 to #4 were made to the design shown in Figures 45 and 46, with a primary coil running the whole length of the coil and 2 secondary coils overwound on each half-section.

Repeatability

Between calibrations

In this embodiment, the calibration curve of LVDT #0 was measured on three occasions. Across the whole calibration range of 27mm, the maximum deviation from the mean reading was +/- 3 counts (0.79%) and the standard deviation of 1.12 counts
5 (0.29%).

Between coils

Three identical examples of the same design, LVDTs #1, #2, #3 were constructed and calibrated. The results of the calibration curves are shown in Figures 8 and 9 below. Across the whole calibration range, the overall standard deviation between readings of
10 the three coils was 5.82 counts (1.10% of range). This equates to a maximum positional error of 0.30mm when the reading is calibrated in mm.

Since the mechanical system provides a known starting reference, all measurements are relative to the zero point. This error should not affect the penetrating
15 member positional accuracy.

Temperature Stability

The sensitivity of the LVDT and its drive electronics to temperature variation was measured across the usable temperature range, by both heating and cooling the prototype assembly and performing a calibration. The results are displayed in Figures 50
20 and 51. Figures 48 and 49: LVDT #2 Combined calibration chart - hot and cold readings, positional errors in across temperatue range across usable positon range

In one embodiment, the maximum error in ADC count measured over the temperature range would equate to an error of 0.9mm in the worst case. The maximum positional error within the usable range was 0.48mm. This level of error requires further
25 attention to reduce it because this error will be evident in the course of the normal use of the product. It is thought that this is caused by changes in the resistance of the LVDT coil; temperature-resistance changes within the op-amps and the ancillary resistors, and especially the primary drive circuit.

Resolution

30 The resolution of the LVDT module depends on two factors:

The ADC resolution

The rate of change of output amplitude of the secondary coil with respect to the core position: the higher the better.

For this embodiment, the ADC resolution was fixed at 10-bits. Within the range provided by this, the resolution was limited by the maximum signal amplitude which could be achieved from the secondary coil amplifier. Calibration curves for the first prototype LVDT, #0, and for #1- #3 are shown in figures 51 and 52 below. The usable range of the LVDT is highlighted on each figure. For LVDT 0, figure 7 shows that the raw ADC count changes rapidly with position between 7 and 14mm offset and this is the region where the resolution was highest on this LVDT prototype. Over this range, the resolution varied between 0.025mm and 0.014mm. Figures 52 and 53: Calibration charts – LVDT #0, and LVDTs #1 - #3 (combined)

To check the effect of counterwinding, one of the secondary coils was wound in the opposite sense to all the other coils. As expected, the effect was the same as that of switching coil polarity, with no change in the amplitude / position relationship.

Physical dimensions

For one embodiment, Some 2D sketches of the LVDT bobbin are shown in Figures 54 and 55. The overall length is governed by the throw distance and the diameter is governed by the minimum achievable wall thicknesses and the number of turns wound. The representative outer dimensions OD for this iteration were OD 3.65mm, length 23mm. This would create a packaged volume of approximately 340mm³. For the encoder, the volume to be packaged is approximately 1100 mm³. In a future design iteration, the number of turns wound could be reduced by approximately 25% before any detrimental effects were noticed which would further benefit packaging.

Effect of core size

In one embodiment, a calibration was attempted using an 8mm core, and the result was that the level of coupling was decreased but the overall range between secondary peaks was unaffected. This suggests that reducing the core length will have no beneficial effect in increasing the usable throw distance. It is estimated that this can be reduced by at least 50% in further trials. In one embodiment, the following

Parameter	LVDT module
Stability	Coil-to-coil repeatability: 0.30mm Temperature: 0.50mm over operating temp range and usable calibration range
Range / Resolution	8mm / 20µm
Response time	On-demand. 200kHz / 5µs with 3694 microcontroller. Tested at 100kHz / 10µs
Moving mass	0.163g
Size	340mm ³

Coils	Parameter	Value
#0	Turns ratio – (primary / secondary A, secondary B)	1:1:1
	Primary resistance	1.1ohm
	Resolution	20µm
	Secondary resistance	2.1ohm
	Repeatability	0.29%
	Range	7mm
#1 - #3	Turns ratio – (primary / secondary A, secondary B)	1:1:1
	Primary resistance	32ohm
	Secondary resistance	34.5 / 34.5 ohm
	Repeatability between coils	1.10%
	Resolution	20µm
	Range at this resolution	7mm

In yet another embodiment, a solenoid-based actuator has been developed to move penetrating members into skin for the purpose of collecting blood for the analysis of blood glucose. To reduce pain and improve blood yield, the speed, acceleration, and position of the actuating solenoid is controlled. In this embodiment, control is provided by a processor that monitors the actuation cycle and modulates the electrical power to the solenoid. Commercially available position transducers (such as Hewlett Packard HEDS9731) are being used to provide actuator position information.

In one embodiment, the present invention consists of a Linear Variable Differential Position Transducer (LVDT) that has been modified to provide a low profile design. LVDT's are commonly available such as from Solartron (704) 868-4661 and consist of adjacent cylindrically wound coils with a soft iron coupling slug that moves inside the coils. Energy from an excitation coil is coupled into two secondary coils in proportion to the slug position within the coils. Available LVDT's are cylindrical so the height and width are equal.

Referring now to Figure 10, to create a more compact LVDT, in one embodiment, the excitation and driven coils could be wound as flat coils and placed next to each other in a plane. The moving slug 100 would then take the form of a flat plate of soft iron that moves in a plane parallel to the coil plane, and close to it. The resulting transducer 102 would be thin relative to its width and would make more efficient use of space. The price for a more compact design would be efficiency of coupling, and possibly accuracy.

One arrangement of coils, as illustrated in Figure 54, would consist of a large rectangular driving coil wound in a flat open shape. Inside the driver coil 104, two smaller rectangular or square coils 106 would be mounted side-by-side. The slug would move along the long axis of the driving coil. Figures 55 and 56 provide views of the coil. Specifically, Figure 56 shows the slug removed and the coils 104 and 106 exposed.

Another arrangement of coils would be similar, with sensing coils inside a driving coil, but the coils may be traces etched onto a thin PCB or flex circuit. Multiple PCB's and/or flex circuits could be stacked to provide more coil turns.

An alternate arrangement of the slug would consist of a soft iron plate of sheet metal, formed into a "U" so as to enclose the coils on three sides. This wrap-around slug would provide better coupling between the coils at the cost of more moving mass.

In this embodiment, the primary coil was supplied with 13 Amp turns. The secondary coils have 640 turns each. The emf induced in each secondary coil was determined at various positions of the c-slug, from fully covering the 2 coils to fully uncovering them. Figure 57 below shows the differential between the 2 coils emf and their sum also. The values were obtained at 60 Hz in the primary coil. The sensitivity appears to be about 3 mV/mm, in the linear section of the sum curve.

Figure 58 below is similar to the one above but the values were obtained at 6,000 Hz in the primary coil. The sensitivity appears to have increased to 22 mV/mm, in the linear section.

In one embodiment, the linear section of the travel appears to be about 3.5 mm. This can be increased to 8 mm by doubling the width of the secondary coils to 4 mm each. The number of turns of these secondary coils is determined by the packing factor and the fineness of the wire used. The number of turns and current in the primary coil can be chosen for the most appropriate match with the available supply to produce the necessary amp-turns.

In one embodiment, the C-slug was assigned mild steel for material. The thickness can be reduced significantly since the levels of flux density in the present cross-section are very low. It is probably sufficient to have a steel sheet on one side of the coils only to produce the required linear emf curves. The material of the frame can be either magnetic or non-magnetic, since no effect was seen on the emf values.

In one embodiment, a position transducer for detecting mechanism component position is provided. The transducer functions by winding flat coils and placing driver and driven coils inside each other; coupling coils with a moving flat soft iron plate or forming the moving soft iron plate so it encloses the coils on three or more sides. The coils may be created by etching a PCB or flex circuit. A position transducer is described that works on the LVDT principle and is very compact. The low-profile form of the transducer is achieved by using flat, coplanar coils and a flat coupling slug.

In one embodiment, the shaft 110 may be covered with a magnetic layer. Plating of magnetic material on the carbon fiber rod would reduce the mass of the slug. Moving mass reduction will allow for improved acceleration.

Referring now to Figure 59, a still further embodiment of a cartridge according to the present invention will be described. Figure 59 shows one embodiment of a cartridge 900 which may be removably inserted into an apparatus for driving penetrating members to pierce skin or tissue. The cartridge 900 has a plurality of penetrating members 902 that may be individually or otherwise selectively actuated so that the penetrating members 902 may extend outward from the cartridge, as indicated by arrow 904, to penetrate tissue. In the present embodiment, the cartridge 900 may be based on a flat disc with a number of penetrating members such as, but in no way limited to, (25, 50, 75, 100, ...) arranged radially on the disc or cartridge 800. It should be understood that although the cartridge 900 is shown as a disc or a disc-shaped housing, other shapes or configurations of the cartridge may also work without departing from the spirit of the present invention of placing a plurality of penetrating members to be engaged, singly or in some combination, by a penetrating member driver.

Each penetrating member 902 may be contained in a cavity 906 in the cartridge 900 with the penetrating member's sharpened end facing radially outward and may be in the same plane as that of the cartridge. The cavity 906 may be molded, pressed, forged, or otherwise formed in the cartridge. Although not limited in this manner, the ends of the cavities 906 may be divided into individual fingers (such as one for each cavity) on the outer periphery of the disc. The particular shape of each cavity 906 may be designed to suit the size or shape of the penetrating member therein or the amount of space desired for placement of the analyte detecting members 808. For example and not limitation, the cavity 906 may have a V-shaped cross-section, a U-shaped cross-section, C-shaped cross-section, a multi-level cross section or the other cross-sections. The opening 810 through which a penetrating member 902 may exit to penetrate tissue may also have a variety of shapes, such as but not limited to, a circular opening, a square or rectangular opening, a U-shaped opening, a narrow opening that only allows the penetrating member to pass, an opening with more clearance on the sides, a slit, a configuration as shown in Figure 75, or the other shapes.

In this embodiment, after actuation, the penetrating member 902 is returned into the cartridge and may be held within the cartridge 900 in a manner so that it is not able to be used again. By way of example and not limitation, a used penetrating member may be returned into the cartridge and held by the launcher in position until the next lancing event. At the time of the next lancing, the launcher may disengage the used penetrating member with the cartridge 900 turned or indexed to the next clean penetrating member such that the cavity holding the used penetrating member is position so that it is not accessible to the user (i.e. turn away from a penetrating member exit opening). In some embodiments, the tip of a used penetrating member may be driven into a protective stop that hold the penetrating member in place after use. The cartridge 900 is replaceable with a new cartridge 900 once all the penetrating members have been used or at such other time or condition as deemed desirable by the user.

Referring still to the embodiment in Figure 59, the cartridge 900 may provide sterile environments for penetrating members via seals, foils, covers, polymeric, or similar materials used to seal the cavities and provide enclosed areas for the penetrating members to rest in. In the present embodiment, a foil or seal layer 920 is applied to one surface of the cartridge 900. The seal layer 920 may be made of a variety of materials such as a metallic foil or other seal materials and may be of a tensile strength and other quality that may provide a sealed, sterile environment until the seal layer 920 is penetrate by a suitable or penetrating device providing a preselected or selected amount of force to open the sealed, sterile environment. Each cavity 906 may be individually sealed with a layer 920 in a manner such that the opening of one cavity does not interfere with the sterility in an adjacent or other cavity in the cartridge 800. As seen in the embodiment of Figure 59, the seal layer 920 may be a planar material that is adhered to a top surface of the cartridge 800.

Depending on the orientation of the cartridge 900 in the penetrating member driver apparatus, the seal layer 920 may be on the top surface, side surface, bottom surface, or other positioned surface. For ease of illustration and discussion of the embodiment of Figure 59, the layer 920 is placed on a top surface of the cartridge 800. The cavities 906 holding the penetrating members 902 are sealed on by the foil layer 920 and thus create the sterile environments for the penetrating members. The foil layer 920 may seal a plurality of cavities 906 or only a select number of cavities as desired.

In a still further feature of Figure 59, the cartridge 900 may optionally include a plurality of analyte detecting members 908 on a substrate 922 which may be attached to a bottom surface of the cartridge 900. The substrate may be made of a material such as, but not limited to, a polymer, a foil, or other material suitable for attaching to a cartridge and holding the analyte detecting members 908. As seen in Figure 59, the substrate 922 may hold a plurality of analyte detecting members, such as but not limited to, about 10-50, 50-100, or other combinations of analyte detecting members. This facilitates the assembly and integration of analyte detecting members 908 with cartridge 900. These analyte detecting members 908 may enable an integrated body fluid sampling system where the penetrating members 902 create a wound tract in a target tissue, which expresses body fluid that flows into the cartridge for analyte detection by at least one of the analyte detecting members 908. The substrate 922 may contain any number of analyte detecting members 908 suitable for detecting analytes in cartridge having a plurality of cavities 906. In one embodiment, many analyte detecting members 908 may be printed onto a single substrate 922 which is then adhered to the cartridge to facilitate manufacturing and simplify assembly. The analyte detecting members 908 may be electrochemical in nature. The analyte detecting members 908 may further contain enzymes, dyes, or other detectors which react when exposed to the desired analyte. Additionally, the analyte detecting members 908 may comprise of clear optical windows that allow light to pass into the body fluid for analyte analysis. The number, location, and type of analyte detecting member 908 may be varied as desired, based in part on the design of the cartridge, number of analytes to be measured, the need for analyte detecting member calibration, and the sensitivity of the analyte detecting members. If the cartridge 900 uses an analyte detecting member arrangement where the analyte detecting members are on a substrate attached to the bottom of the cartridge, there may be through holes (as shown in Figure 76), wicking elements, capillary tube or other devices on the cartridge 900 to allow body fluid to flow from the cartridge to the analyte detecting members 908 for analysis. In other configurations, the analyte detecting members 908 may be printed, formed, or otherwise located directly in the cavities housing the penetrating members 902 or areas on the cartridge surface that receive blood after lancing.

The use of the seal layer 920 and substrate or analyte detecting member layer 822 may facilitate the manufacture of these cartridges 10. For example, a single seal layer

920 may be adhered, attached, or otherwise coupled to the cartridge 900 as indicated by arrows 924 to seal many of the cavities 906 at one time. A sheet 922 of analyte detecting members may also be adhered, attached, or otherwise coupled to the cartridge 900 as indicated by arrows 925 to provide many analyte detecting members on the cartridge at one time. During manufacturing of one embodiment of the present invention, the cartridge 900 may be loaded with penetrating members 902, sealed with layer 920 and a temporary layer (not shown) on the bottom where substrate 922 would later go, to provide a sealed environment for the penetrating members. This assembly with the temporary bottom layer is then taken to be sterilized. After sterilization, the assembly is taken to a clean room (or it may already be in a clean room or equivalent environment) where the temporary bottom layer is removed and the substrate 922 with analyte detecting members is coupled to the cartridge as shown in Figure 59. This process allows for the sterile assembly of the cartridge with the penetrating members 902 using processes and/or temperatures that may degrade the accuracy or functionality of the analyte detecting members on substrate 922. As a nonlimiting example, the entire cartridge 900 may then be placed in a further sealed container such as a pouch, bag, plastic molded container, etc...to facilitate contact, improve ruggedness, and/or allow for easier handling.

In some embodiments, more than one seal layer 920 may be used to seal the cavities 906. As examples of some embodiments, multiple layers may be placed over each cavity 906, half or some selected portion of the cavities may be sealed with one layer with the other half or selected portion of the cavities sealed with another sheet or layer, different shaped cavities may use different seal layer, or the like. The seal layer 920 may have different physical properties, such as those covering the penetrating members 902 near the end of the cartridge may have a different color such as red to indicate to the user (if visually inspectable) that the user is down to say 10, 5, or other number of penetrating members before the cartridge should be changed out.

Referring now to Figure 60, one embodiment of an apparatus 980 using a radial cartridge 900 with a penetrating member driver 982 is shown. A contoured surface 884 is located near a penetrating member exit port 986, allowing for a patient to place their finger in position for lancing. Although not shown, the apparatus 980 may include a human readable or other type of visual display to relay status to the user. The display

may also show measured analyte levels or other measurement or feedback to the user without the need to plug apparatus 980 or a separate test strip into a separate analyte reader device. The apparatus 980 may include a processor or other logic for actuating the penetrating member or for measuring the analyte levels. The cartridge 900 may be loaded into the apparatus 980 by opening a top housing of the apparatus which may be hinged or removably coupled to a bottom housing. The cartridge 900 may also be drawn into the apparatus 980 using a loading mechanism similar in spirit to that found on a compact disc player or the like. In such an embodiment, the apparatus may have a slot (similar to a CD player in an automobile) that allows for the insertion of the cartridge 900 into the apparatus 980 which is then automatically loaded into position or otherwise seated in the apparatus for operation therein. The loading mechanism may be mechanically powered or electrically powered. In some embodiments, the loading mechanism may use a loading tray in addition to the slot. The slot may be placed higher on the housing so that the cartridge 900 will have enough clearance to be loaded into the device and then dropped down over the penetrating member driver 982. The cartridge 900 may have an indicator mark or indexing device that allows the cartridge to be properly aligned by the loading mechanism or an aligning mechanism once the cartridge 900 is placed into the apparatus 980. The cartridge 900 may rest on a radial platform that rotates about the penetrating member driver 982, thus providing a method for advancing the cartridge to bring unused penetrating members to engagement with the penetrating member driver. The cartridge 800 on its underside or other surface, may be shaped or contoured such as with notches, grooves, tractor holes, optical markers, or the like to facilitate handling and/or indexing of the cartridge. These shapes or surfaces may also be varied so as to indicate that the cartridge is almost out of unused penetrating members, that there are only five penetrating members left, or some other cartridge status indicator as desired.

A suitable method and apparatus for loading penetrating members has been described previously in commonly assigned, copending U.S. patent applications Attorney Docket 38187-2589 and 38187-2590, and are included here by reference for all purposes. Suitable devices for engaging the penetrating members and for removing protective materials associated with the penetrating member cavity are described in commonly assigned, copending U.S. patent applications Attorney Docket 38187-2601

and 38187-2602, and are included here by reference for all purposes. For example in the embodiment of Figure 59, the foil or seal layer 920 may cover the cavity by extending across the cavity along a top surface 990 and down along the angled surface 892 to provide a sealed, sterile environment for the penetrating member and sensors therein. A
5 piercing element described in U.S. patent applications Attorney Docket 38187-2602 has a piercing element and then a shaped portion behind the element which pushes the foil to the sides of the cavity or other position so that the penetrating member 902 may be actuated and body fluid may flow into the cavity.

Referring now to Figure 61, one embodiment of a device that may use a disc 900
10 is shown. This embodiment of device 1000 include a display 1002 that shows lancing performance and setting such as penetration depth setting the like. Various buttons 1004 may also be placed on the housing to adjust settings and/or to activate lancing.

It should be understood that device 1000 may include a processor for
15 implementing any of the control methodologies set forth herein. The processor may control the penetrating member driver and/or active braking device such a pads, stops, dampers, dashpots and other mechanism to control penetrating member speed. The characteristic phases of penetrating member advancement and retraction can be plotted on a graph of force versus time illustrating the force exerted by the penetrating member driver on the penetrating member to achieve the desired displacement and velocity
20 profile. The characteristic phases are the penetrating member introduction phase A-C where the penetrating member is longitudinally advanced into the skin, the penetrating member rest phase D where the penetrating member terminates its longitudinal movement reaching its maximum depth and becoming relatively stationary, and the penetrating member retraction phase E-G where the penetrating member is longitudinally
25 retracted out of the skin. The duration of the penetrating member retraction phase E-G is longer than the duration of the penetrating member introduction phase A-C, which in turn is longer than the duration of the penetrating member rest phase D.

The introduction phase further comprises a penetrating member launch phase prior to A when the penetrating member is longitudinally moving through air toward the
30 skin, a tissue contact phase at the beginning of A when the distal end of the penetrating member makes initial contact with the skin, a tissue deformation phase A when the skin bends depending on its elastic properties which are related to hydration and thickness, a

tissue lancing phase which comprises when the penetrating member hits the inflection point on the skin and begins to cut the skin B and the penetrating member continues cutting the skin C. The penetrating member rest phase D is the limit of the penetration of the penetrating member into the skin. Pain is reduced by minimizing the duration of the penetrating member introduction phase A-C so that there is a fast incision to a certain penetration depth regardless of the duration of the deformation phase A and inflection point cutting B which will vary from user to user. Success rate is increased by measuring the exact depth of penetration from inflection point B to the limit of penetration in the penetrating member rest phase D. This measurement allows the penetrating member to always, or at least reliably, hit the capillary beds which are a known distance underneath the surface of the skin.

The penetrating member retraction phase further comprises a primary retraction phase E when the skin pushes the penetrating member out of the wound tract, a secondary retraction phase F when the penetrating member starts to become dislodged and pulls in the opposite direction of the skin, and penetrating member exit phase G when the penetrating member becomes free of the skin. Primary retraction is the result of exerting a decreasing force to pull the penetrating member out of the skin as the penetrating member pulls away from the finger. Secondary retraction is the result of exerting a force in the opposite direction to dislodge the penetrating member. Control is necessary to keep the wound tract open as blood flows up the wound tract. Blood volume is increased by using a uniform velocity to retract the penetrating member during the penetrating member retraction phase E-G regardless of the force required for the primary retraction phase E or secondary retraction phase F, either of which may vary from user to user depending on the properties of the user's skin.

Displacement versus time profile of a penetrating member for a controlled penetrating member retraction can be plotted. Velocity vs. time profile of the penetrating member for the controlled retraction can also be plotted. The penetrating member driver controls penetrating member displacement and velocity at several steps in the lancing cycle, including when the penetrating member cuts the blood vessels to allow blood to pool 2130, and as the penetrating member retracts, regulating the retraction rate to allow the blood to flood the wound tract while keeping the wound flap from sealing the channel 2132 to permit blood to exit the wound.

The tenting process and retrograde motion of the penetrating member during the lancing cycle can be illustrated graphically which shows both a velocity versus time graph and a position versus time graph of a penetrating member tip during a lancing cycle that includes elastic and inelastic tenting. From point 0 to point A, the penetrating member is being accelerated from the initialization position or zero position. From point A to point B, the penetrating member is in ballistic or coasting mode, with no additional power being delivered. At point B, the penetrating member tip contacts the tissue and begins to tent the skin until it reaches a displacement C. As the penetrating member tip approaches maximum displacement, braking force is applied to the penetrating member until the penetrating member comes to a stop at point D. The penetrating member then recoils in a retrograde direction during the settling phase of the lancing cycle indicated between D and E. Note that the magnitude of inelastic tenting indicated in Figure 148 is exaggerated for purposes of illustration.

The amount of inelastic tenting indicated by Z tends to be fairly consistent and small compared to the magnitude of the elastic tenting. Generally, the amount of inelastic tenting Z can be about 120 to about 140 microns. As the magnitude of the inelastic tenting has a fairly constant value and is small compared to the magnitude of the elastic tenting for most patients and skin types, the value for the total amount of tenting for the penetration stroke of the penetrating member is effectively equal to the rearward displacement of the penetrating member during the settling phase as measured by the processor 193 plus a predetermined value for the inelastic recoil, such as 130 microns. Inelastic recoil for some embodiments can be about 100 to about 200 microns. The ability to measure the magnitude of skin tenting for a patient is important to controlling the depth of penetration of the penetrating member tip as the skin is generally known to vary in elasticity and other parameters due to age, time of day, level of hydration, gender and pathological state.

This value for total tenting for the lancing cycle can then be used to determine the various characteristics of the patient's skin. Once a body of tenting data is obtained for a given patient, this data can be analyzed in order to predict the total penetrating member displacement, from the point of skin contact, necessary for a successful lancing procedure. This enables the tissue penetration device to achieve a high success rate and minimize pain for the user. A rolling average table can be used to collect and store the

tenting data for a patient with a pointer to the last entry in the table. When a new entry is input, it can replace the entry at the pointer and the pointer advances to the next value. When an average is desired, all the values are added and the sum divided by the total number of entries by the processor 193. Similar techniques involving exponential decay (multiply by .95, add 0.05 times current value, etc.) are also possible.

5 With regard to tenting of skin generally, some typical values relating to penetration depth are now discussed. A cross sectional view of the layers of the skin can be shown. In order to reliably obtain a useable sample of blood from the skin, it is desirable to have the penetrating member tip reach the venuolar plexus of the skin. The
10 stratum corneum is typically about 0.1 to about 0.6 mm thick and the distance from the top of the dermis to the venuole plexus can be from about 0.3 to about 1.4 mm. Elastic tenting can have a magnitude of up to about 2 mm or so, specifically, about 0.2 to about 2.0 mm, with an average magnitude of about 1 mm. This means that the amount of penetrating member displacement necessary to overcome the tenting can have a
15 magnitude greater than the thickness of skin necessary to penetrate in order to reach the venuolar plexus. The total penetrating member displacement from point of initial skin contact may have an average value of about 1.7 to about 2.1 mm. In some embodiments, penetration depth and maximum penetration depth may be about 0.5 mm to about 5 mm, specifically, about 1 mm to about 3 mm. In some embodiments, a maximum penetration
20 depth of about 0.5 to about 3 mm is useful.

In some embodiments, the penetrating member is withdrawn with less force and a lower speed than the force and speed during the penetration portion of the operation cycle. Withdrawal speed of the penetrating member in some embodiments can be about 0.004 to about 0.5 m/s, specifically, about 0.006 to about 0.01 m/s. In other
25 embodiments, useful withdrawal velocities can be about 0.001 to about 0.02 meters per second, specifically, about 0.001 to about 0.01 meters per second. For embodiments that use a relatively slow withdrawal velocity compared to the penetration velocity, the withdrawal velocity may up to about 0.02 meters per second. For such embodiments, a ratio of the average penetration velocity relative to the average withdrawal velocity can
30 be about 100 to about 1000. In embodiments where a relatively slow withdrawal velocity is not important, a withdrawal velocity of about 2 to about 10 meters per second may be used.

Another example of an embodiment of a velocity profile for a penetrating member can be seen shown, which illustrates a penetrating member profile with a fast entry velocity and a slow withdrawal velocity. A lancing profile showing velocity of the penetrating member versus position. The lancing profile starts at zero time and position and shows acceleration of the penetrating member towards the tissue from the electromagnetic force generated from the electromagnetic driver. At point A, the power is shut off and the penetrating member begins to coast until it reaches the skin indicated by B at which point, the velocity begins to decrease. At point C, the penetrating member has reached maximum displacement and settles momentarily, typically for a time of about 8 milliseconds.

A retrograde withdrawal force is then imposed on the penetrating member by the controllable driver, which is controlled by the processor to maintain a withdrawal velocity of no more than about 0.006 to about 0.01 meters/second. The same cycle is illustrated in the velocity versus time plot of Figure 151 where the penetrating member is accelerated from the start point to point A. The penetrating member coasts from A to B where the penetrating member tip contacts tissue 233. The penetrating member tip then penetrates the tissue and slows with braking force eventually applied as the maximum penetration depth is approached. The penetrating member is stopped and settling between C and D. At D, the withdrawal phase begins and the penetrating member is slowly withdrawn until it returns to the initialization point shown by E. Note that retrograde recoil from elastic and inelastic tenting was not shown in the lancing profiles for purpose of illustration and clarity.

In another embodiment, the withdrawal phase may use a dual speed profile, with the slow .006 to .01 meter per second speed used until the penetrating member is withdrawn past the contact point with the tissue, then a faster speed of .01 to 1 meters per second may be used to shorten the complete cycle.

While the invention has been described and illustrated with reference to certain particular embodiments thereof, those skilled in the art will appreciate that various adaptations, changes, modifications, substitutions, deletions, or additions of procedures and protocols may be made without departing from the spirit and scope of the invention. For example, with any of the above embodiments, the location of the penetrating member drive device may be varied, relative to the penetrating members or the cartridge.

With any of the above embodiments, the penetrating member tips may be uncovered during actuation (i.e. penetrating members do not pierce the penetrating member enclosure or protective foil during launch). With any of the above embodiments, the penetrating members may be a bare penetrating member during launch. With any of the
5 above embodiments, the penetrating members may be bare penetrating members prior to launch as this may allow for significantly tighter densities of penetrating members. In some embodiments, the penetrating members may be bent, curved, textured, shaped, or otherwise treated at a proximal end or area to facilitate handling by an actuator. The penetrating member may be configured to have a notch or groove to facilitate coupling to
10 a gripper. The notch or groove may be formed along an elongate portion of the penetrating member. With any of the above embodiments, the cavity may be on the bottom or the top of the cartridge, with the gripper on the other side. In some embodiments, analyte detecting members may be printed on the top, bottom, or side of the cavities. The front end of the cartridge maybe in contact with a user during lancing.
15 The same driver may be used for advancing and retraction of the penetrating member. The penetrating member may have a diameters and length suitable for obtaining the blood volumes described herein. The penetrating member driver may also be in substantially the same plane as the cartridge. The driver may use a through hole or other opening to engage a proximal end of a penetrating member to actuate the penetrating
20 member along a path into and out of the tissue.

Any of the features described in this application or any reference disclosed herein may be adapted for use with any embodiment of the present invention. For example, the devices of the present invention may also be combined for use with injection penetrating members or needles as described in commonly assigned, copending U.S. Patent
25 Application Ser. No. 10/127,395 (Attorney Docket No. 38187-2551) filed April 19, 2002. An analyte detecting member to detect the presence of foil may also be included in the lancing apparatus. For example, if a cavity has been used before, the foil or sterility barrier will be punched. The analyte detecting member can detect if the cavity is
30 fresh or not based on the status of the barrier. It should be understood that in optional embodiments, the sterility barrier may be designed to pierce a sterility barrier of thickness that does not dull a tip of the penetrating member. The lancing apparatus may also use improved drive mechanisms. For example, a solenoid force generator may be

improved to try to increase the amount of force the solenoid can generate for a given current. A solenoid for use with the present invention may have five coils and in the present embodiment the slug is roughly the size of two coils. One change is to increase the thickness of the outer metal shell or windings surround the coils. By increasing the thickness, the flux will also be increased. The slug may be split; two smaller slugs may also be used and offset by $\frac{1}{2}$ of a coil pitch. This allows more slugs to be approaching a coil where it could be accelerated. This creates more events where a slug is approaching a coil, creating a more efficient system.

In another optional alternative embodiment, a gripper in the inner end of the protective cavity may hold the penetrating member during shipment and after use, eliminating the feature of using the foil, protective end, or other part to retain the used penetrating member. Some other advantages of the disclosed embodiments and features of additional embodiments include: same mechanism for transferring the used penetrating members to a storage area; a high number of penetrating members such as 25, 50, 75, 100, 500, or more penetrating members may be put on a disk or cartridge; molded body about a lancet becomes unnecessary; manufacturing of multiple penetrating member devices is simplified through the use of cartridges; handling is possible of bare rods metal wires, without any additional structural features, to actuate them into tissue; maintaining extreme (better than 50 micron -lateral- and better than 20 micron vertical) precision in guiding; and storage system for new and used penetrating members, with individual cavities/slots is provided. The housing of the lancing device may also be sized to be ergonomically pleasing. In one embodiment, the device has a width of about 56 mm, a length of about 105 mm and a thickness of about 15 mm. Additionally, some embodiments of the present invention may be used with non-electrical force generators or drive mechanism. For example, the punch device and methods for releasing the penetrating members from sterile enclosures could be adapted for use with spring based launchers. The gripper using a frictional coupling may also be adapted for use with other drive technologies.

Still further optional features may be included with the present invention. For example, with any of the above embodiments, the location of the penetrating member drive device may be varied, relative to the penetrating members or the cartridge. With any of the above embodiments, the penetrating member tips may be uncovered during

actuation (i.e. penetrating members do not pierce the penetrating member enclosure or protective foil during launch). The penetrating members may be a bare penetrating member during launch. In some embodiments, the penetrating member may be a patent needle. The same driver may be used for advancing and retraction of the penetrating member. Different analyte detecting members detecting different ranges of glucose concentration, different analytes, or the like may be combined for use with each penetrating member. Non-potentiometric measurement techniques may also be used for analyte detection. For example, direct electron transfer of glucose oxidase molecules adsorbed onto carbon nanotube powder microelectrode may be used to measure glucose levels. In some embodiments, the analyte detecting members may formed to flush with the cartridge so that a "well" is not formed. In some other embodiments, the analyte detecting members may formed to be substantially flush (within 200 microns or 100 microns) with the cartridge surfaces. In all methods, nanoscopic wire growth can be carried out via chemical vapor deposition (CVD). In all of the embodiments of the invention, preferred nanoscopic wires may be nanotubes. Any method useful for depositing a glucose oxidase or other analyte detection material on a nanowire or nanotube may be used with the present invention. Additionally, for some embodiments, any of the cartridge shown above may be configured without any of the penetrating members, so that the cartridge is simply an analyte detecting device. Still further, the indexing of the cartridge may be such that adjacent cavities may not necessarily be used serially or sequentially. As a nonlimiting example, every second cavity may be used sequentially, which means that the cartridge will go through two rotations before every or substantially all of the cavities are used. As another nonlimiting example, a cavity that is 3 cavities away, 4 cavities away, or N cavities away may be the next one used. This may allow for greater separation between cavities containing penetrating members that were just used and a fresh penetrating member to be used next. For any of the embodiments herein, they may be configured to provide the various velocity profiles described.

This application cross-references commonly assigned copending U.S. Patent Applications Ser. No. 10/323,622 (Attorney Docket No. 38187-2606) filed December 18, 2002; commonly assigned copending U.S. Patent Applications Ser. No. 10/323,623 (Attorney Docket No. 38187-2607) filed December 18, 2002; and commonly assigned

5 copending U.S. Patent Applications Ser. No. 10/323,624 (Attorney Docket No. 38187-2608) filed December 18, 2002. This application is also related to commonly assigned copending U.S. Patent Applications Ser. Nos. 10/335,142, 10/335,215, 10/335,258, 10/335,099, 10/335,219, 10/335,052, 10/335,073, 10/335,220, 10/335,252, 10/335,218, 10/335,211, 10/335,257, 10/335,217, 10/335,212, and 10/335,241, 10/335,183, (Attorney Docket Nos. 38187-2633 through 38187-2652) filed December 31, 2002. This application is also a continuation-in-part of commonly assigned, copending U.S. Patent Application Ser. No. 10/425,815 (Attorney Docket No. 38187-2663) filed May 30, 2003. This application is a continuation-in-part of commonly assigned, copending U.S. Patent Application Ser. No. 10/323,622 (Attorney Docket No. 38187-2606) filed on December 18, 2002, which is a continuation-in-part of commonly assigned, copending U.S. Patent Application Ser. No. 10/127,395 (Attorney Docket No. 38187-2551) filed April 19, 2002. This application is also a continuation-in-part of commonly assigned, copending U.S. Patent Application Ser. No. 10/237,261 (Attorney Docket No. 38187-2595) filed September 5, 2002. This application is further a continuation-in-part of commonly assigned, copending U.S. Patent Application Ser. No. 10/420,535 (Attorney Docket No. 38187-2664) filed April 21, 2003. This application is further a continuation-in-part of commonly assigned, copending U.S. Patent Application Ser. No. 10/335,142 (Attorney Docket No. 38187-2633) filed December 31, 2002. This application is further a continuation-in-part of commonly assigned, copending U.S. Patent Application Ser. No. 10/423,851 (Attorney Docket No. 38187-2657) filed April 24, 2003. This application also claims the benefit of priority from commonly assigned, copending U.S. Provisional Patent Application Ser. No. 60/422,988 (Attorney Docket No. 38187-2601) filed November 1, 2002; commonly assigned, copending U.S. Provisional Patent Application Ser. No. 60/424,429 (Attorney Docket No. 38187-2602) filed November 6, 2002; and commonly assigned, copending U.S. Provisional Patent Application Ser. No. 60/424,429 (Attorney Docket No. 38187-2604) filed November 20, 2002. All applications listed above are incorporated herein by reference for all purposes.

30 The publications discussed or cited herein are provided solely for their disclosure prior to the filing date of the present application. Nothing herein is to be construed as an admission that the present invention is not entitled to antedate such publication by virtue of prior invention. Further, the dates of publication provided may be different from the

actual publication dates which may need to be independently confirmed. All publications mentioned herein are incorporated herein by reference to disclose and describe the structures and/or methods in connection with which the publications are cited. For ease of reference, U.S. Provisional Applications Ser. No. 60/476,584, 5 60/478,040, 60/478,704, 60/478,657, 60/478,682, and 60/507,689 are hereby fully incorporated herein by reference for all purposes.

Expected variations or differences in the results are contemplated in accordance with the objects and practices of the present invention. It is intended, therefore, that the invention be defined by the scope of the claims which follow and that such claims be 10 interpreted as broadly as is reasonable.

WHAT IS CLAIMED IS:

1. A method of controlling a penetrating member, the method comprising:
 - (a) providing a device comprising a penetrating member driver having
5 a position sensor and a processor;
 - (b) accelerating the penetrating member towards a target tissue; and
 - (c) using a control algorithm to control the driver to decelerate the
penetrating member to follow a desired trajectory.
- 10 2. A method of controlling a penetrating member, the method comprising:
 - (a) providing a lancing device comprising a penetrating member
driver having a position sensor and a processor that can determine the relative position
and velocity of the penetrating member based on measuring relative position of the
penetrating member with respect to time;
 - 15 (b) accelerating the penetrating member towards a target tissue; and
 - (c) using an adaptive control algorithm to decelerate the penetrating
member to follow a desired trajectory, wherein the penetrating member is not decelerated
in a sudden manner where the tissue bounds away from the member.
- 20 3. The method of claim 1 feed forward control comprises using a
planned velocity profile to reach a desired depth.
4. The method of claim 1 wherein the magnitude of the known value
of deceleration is determined by the deceleration of the penetrating member due to
intrinsic frictional forces of the lancing device alone.
- 25 5. The method of claim 1 further comprising using a look-up table to
determine penetrating member settings based on a desired penetration depth.
6. A method of controlling penetrating member velocity, the method
comprising:
 - advancing the penetrating member to reach a first desired velocity;
 - providing a controller for applying braking force;

applying variable amounts of braking force and driving force to follow a predicted velocity profile, checking in each braking cycle whether braking force should be varied.

- 5 comprising:
7. A method of controlling penetrating member velocity, the method
- controlling penetrating member depth by using an electronic lancet drive system where inbound penetration of the member to the skin is determined by the amount of force applied by the motor to achieve a certain velocity at impact with the skin.
- 10 8. A method of body fluid sampling comprising:
- moving a penetrating member at conforming to a selectable velocity profile or motion waveform;
- measuring force applied by user to a front end of a lancing device;
- 15 determining amount of tissue tenting;
- recording tenting and force.
9. The method of claim 8 further comprising using force and tenting to determine stratum corneum thickness based on a slope of multiple force and tenting data points.
- 20 10. A device for body fluid sampling usable with a cartridge housing a plurality of penetrating members, the device comprising:
- a housing;
- a penetrating member driver coupled to said housing and for use with said cartridge;
- 25 a processor for controlling said penetrating member driver to move at least one of said penetrating members at velocities which conform with a selectable velocity profile;
- a pressure transducer coupled to a front end of the housing where a user places a target tissue, said transducer sending measurements to the processor, said processor also measuring tenting of the tissue.
- 30 11. The device of claim 10 comprising a window allowing a user to see the cartridge while the cartridge is in said housing.

12. The device of claim
10 comprising display showing device status.
13. The device of claim
10 comprising display showing lancing performance.
- 5 14. The device of claim
10 comprising display showing lancing parameters.
15. The device of claim
10 comprising a single button for actuating said penetrating member
driver along an inbound path into tissue and then an outbound path out of the tissue.
- 10 16. The device of claim
10 wherein said penetrating member driver moves an active one of said
penetrating members along a velocity profile that reduces initial pain and residual pain to
levels below that of known devices.
17. The device of claim
15 10 wherein said penetrating member driver moves an active one of said
penetrating members along a velocity profile that reduces initial pain and residual pain to
levels at least 1.5 times less than that of known devices.
18. The device of claim
20 10 wherein said penetrating member driver moves an active one of said
penetrating members along a velocity profile that reduces residual pain to levels at least 2
times less than that of known devices.
19. A method of determining contact between a tip of a penetrating
member and target tissue of a patient comprising:
- 25 (a) Providing a lancing device comprising a penetrating member
driver having a position sensor and a processor that can determine the relative position
and velocity of the penetrating member based on measuring relative position of the
penetrating member with respect to time;

(b) Measuring a magnitude of deceleration of the penetrating member during at least a portion of the inward cutting stroke of the lancing cycle and comparing the magnitude of the measured deceleration to a known value of deceleration; and

5 (c) Determining contact if the magnitude of the measured deceleration is sufficiently greater than the magnitude of the known value of deceleration..

20. The method of claim 1 wherein the magnitude of the known value of deceleration is determined by the deceleration of the penetrating member due to intrinsic frictional forces of the lancing device alone.

10 21. The method of claim 20 wherein the magnitude of the known value of deceleration is determined empirically by observing the magnitude of deceleration of the penetrating member when the penetrating member is known to be making contact with the target tissue.

15 22. A method of designing a product, the method comprising:
using personality test to determine characteristics of the user;
designing a plurality products designed to appeal to those with certain personalities;

selecting at least one product design based on user personality.

20 23. A method of controlling penetrating member velocity, the method comprising:
advancing the penetrating member to reach a first desired velocity;
providing a controller for applying braking force;

applying variable amounts of braking force based on a desired velocity provide to bring the penetrating member to a stop at a desired depth.

25 24. A method of body fluid sampling comprising:
moving a penetrating member at velocities that conform with a tent and hold lancing velocity profile or motion waveform;
achieving higher rates of spontaneous blood and higher spontaneous yields given the same penetration depth;
achieving lower pain relative to spontaneous blood yield.

25. The device of claim 24 wherein the penetrating member trajectory waveform contains a stationary portion.

26. The device of claim 24 wherein the velocity profile is "tent-and-hold", power requirement to hold.

5 27. The device of claim 24 comprising "tent-and-damped-hold" wherein the penetrating member applies a force only great enough to slow the relaxation of the skin, but not to hold the relaxation of the skin.

28. A method of body fluid sampling, the method comprising:
determining at least one of the following characteristics based on
10 relationship of power used by a penetrating member driver to tent-and-hold, or damp-and-hold:

skin characteristics e.g. hydration, possibly stratum corneum thickness
power used to retract the penetrating member from a given depth or given
skin
15 wound stabilization characteristics used to get the blood out -reorientation of collagen fibers to keep the channel patent.

29. A method for controlling depth of penetrating member motion into a patient, said method comprising:
measuring the amount of skin or tissue tenting of an individual lancing
20 event by actuating said penetrating member into the tissue, measuring a first penetration position, removing all actuation force, measuring a relaxed position, and determining the difference to determine the tenting.

30. The method of claim 29 comprising correcting the desired penetration depth by the amount of tenting.

25 31. The method of claim 29 comprising advancing said penetrating member after measuring the amount of tenting and while the penetrating member remains in the patient, to continue the lancing event in order to achieve a desired depth into the tissue.

32. The method of claim 29 comprising advancing said penetrating member to continue the lancing event in order to achieve a desired depth into the tissue.

33. A method of controlling a penetrating member, the method comprising: [2683]

5 (a) providing a lancing device comprising a penetrating member driver having a position sensor and a processor that can determine the relative position and velocity of the penetrating member based on measuring relative position of the penetrating member with respect to time;

(b) providing a predetermined velocity control trajectory based on a
10 model of the driver and a model of tissue to be contacted; and

(c) using feedforward control to maintain penetrating member velocity along said trajectory.

34. The method of claim 29 feed forward control comprises using a planned velocity profile to reach a desired depth.

15 35. The method of claim 29 wherein the magnitude of the known value of deceleration is determined by the deceleration of the penetrating member due to intrinsic frictional forces of the lancing device alone.

36. The method of claim 29 wherein the magnitude of the known value of deceleration is determined empirically by observing the magnitude of
20 deceleration of the penetrating member when the penetrating member is known to be making contact with the target tissue.

37. A method of controlling penetrating member velocity, the method comprising:

25 advancing the penetrating member to reach a first desired velocity;
providing a controller for applying braking force;
applying variable amounts of braking force and driving force to follow a predicted velocity profile.

38. A method of forming an Linear Variable Differential Transformer comprising:

providing a bobbin with a physical wall for separating coils of one secondary coil from coils of another secondary coil;

winding a plurality of layers of wiring over said bobbin, said layers of wiring wound in a substantially uniforming manner to provide a wound bobbin;

5 calibrating said wound bobbin by using a processor to linearize output from the bobbin.

39. The method of claim 38 wherein the processor uses a lookup table to linearize the output.

40. The method of claim 38 wherein coils of a primary coil are
10 separated from coils of another primary coil by said wall.

41. The method of claim 38 wherein the output from the bobbin is nonlinear and uses a processor to take the output and linearize it.

42. A device for body fluid sampling, the device comprising:
15 a penetrating member driver;
 an LVDT coupled to said driver, wherein said LVDT generates a nonlinear output which is received by a processor which then linearizes the output, said LVDT used to monitor the position of a penetrating member coupled to the driver.

43. A method of controlling penetrating member velocity, the method comprising:
20 advancing the penetrating member to reach a first desired velocity;
 providing a processor coupled to an LVDT, processor linearizing the nonlinear output of the LVDT;
 applying variable amounts of braking force based on a desired velocity provide to bring the penetrating member to a stop at a desired depth based on position
25 feed back from the LVDT.

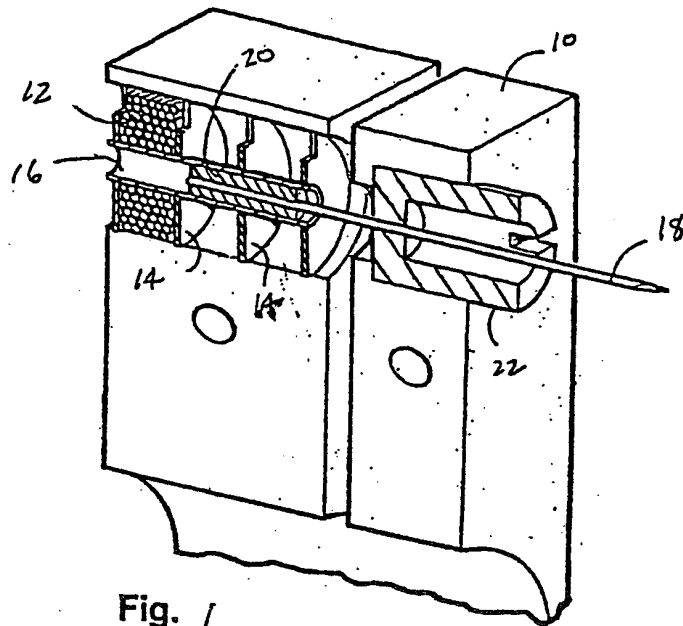

Fig. 1

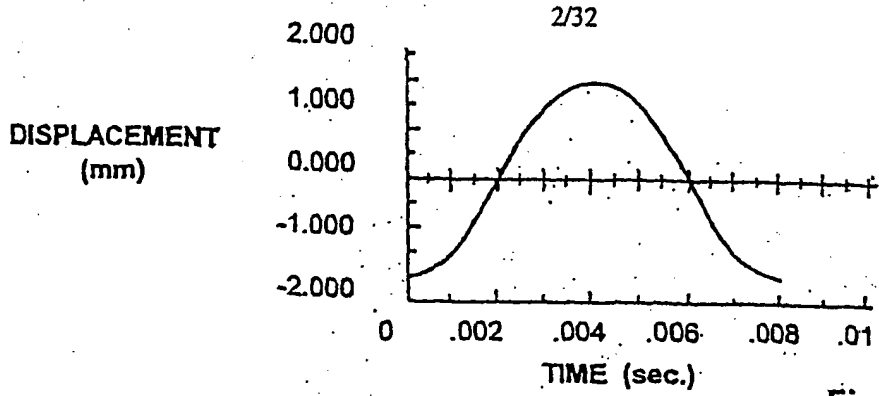

Fig. 24

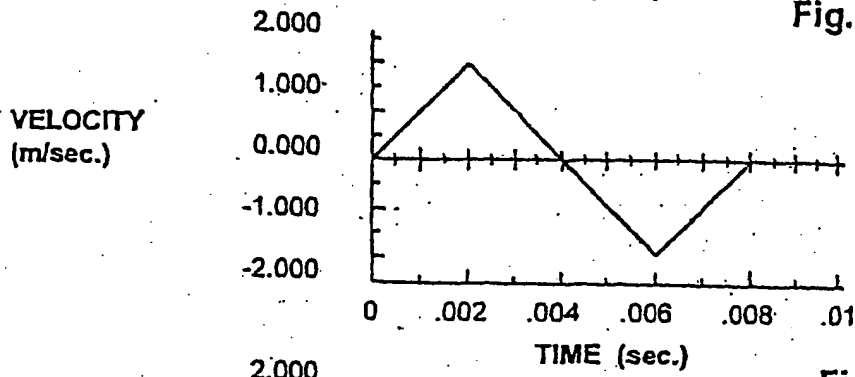

Fig. 29

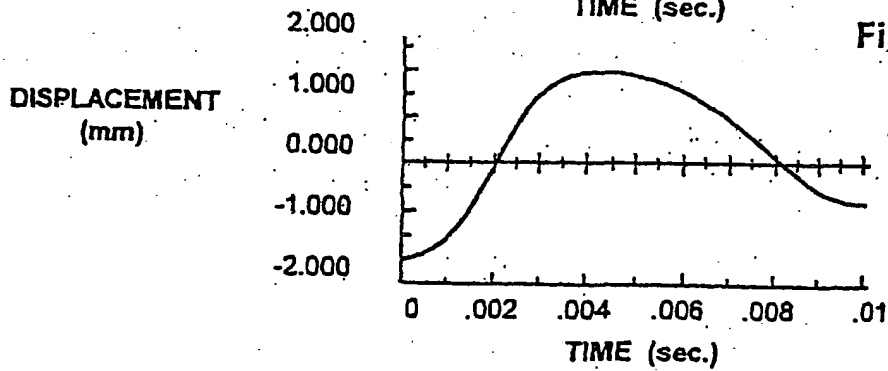

Fig. 2c

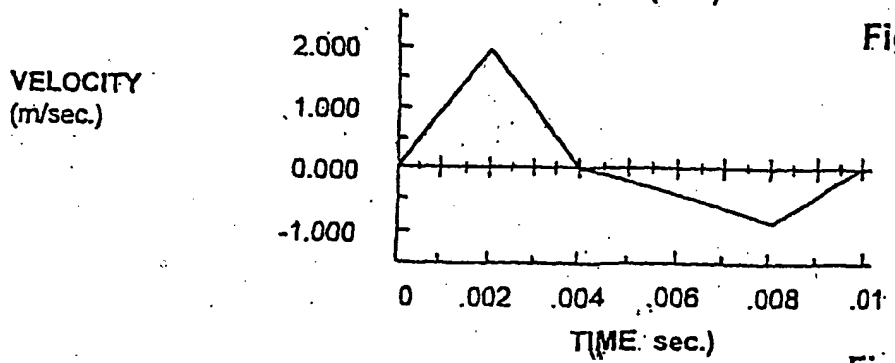

Fig. 2d

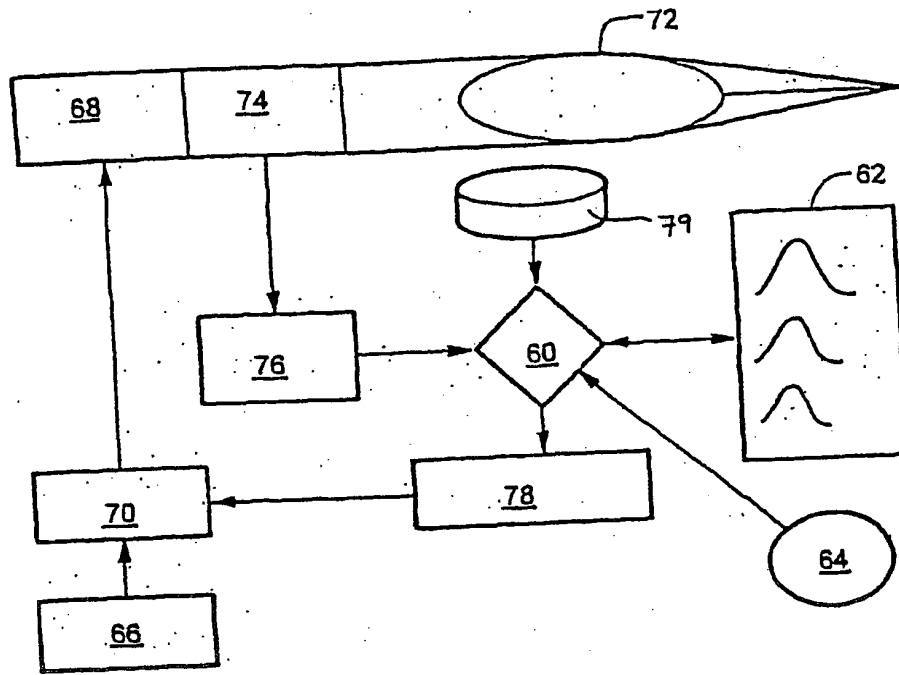

Fig. 3

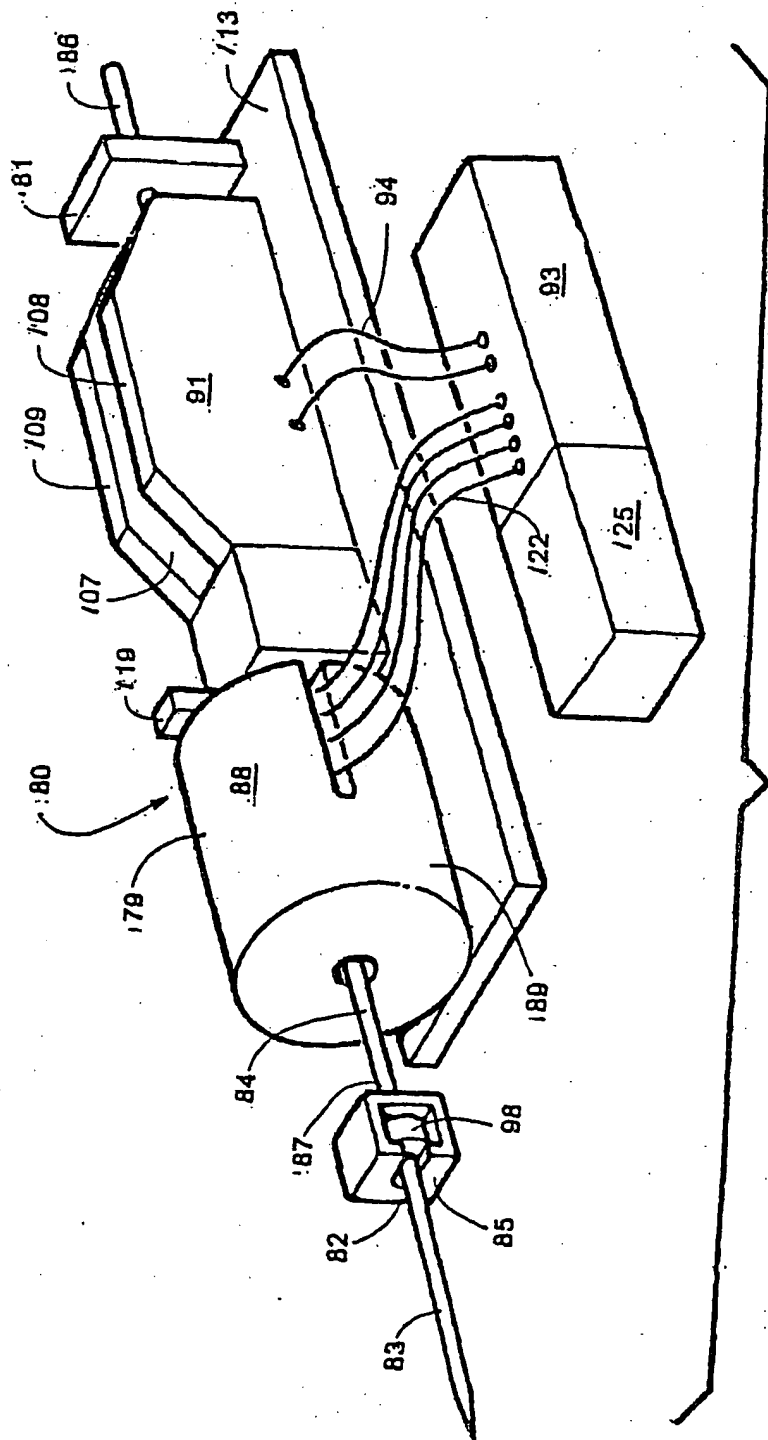

Fig. 4

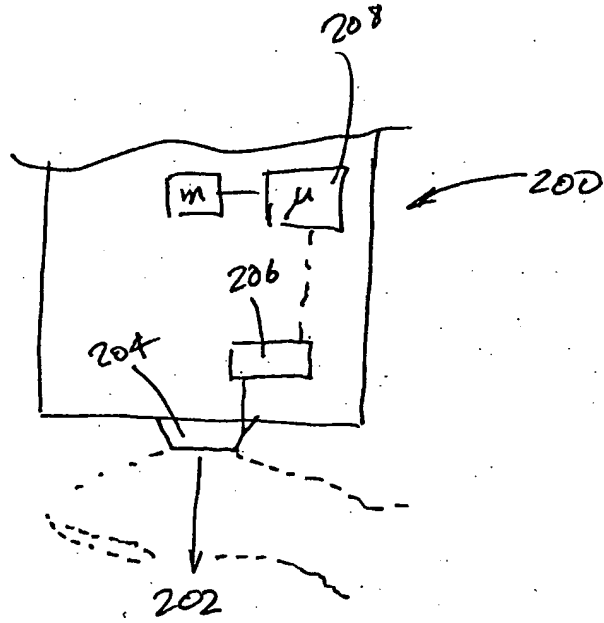

FIG-6

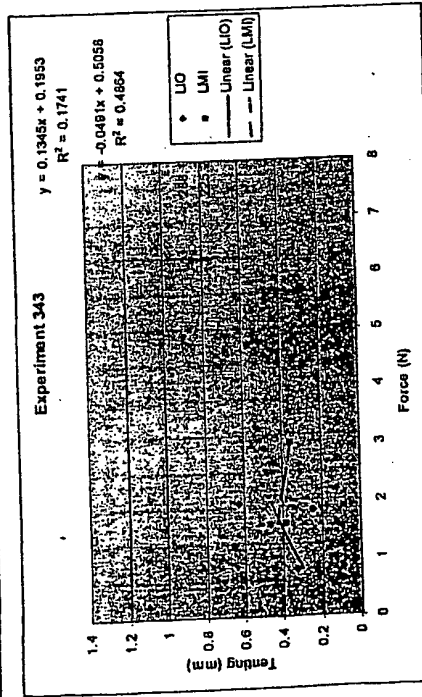
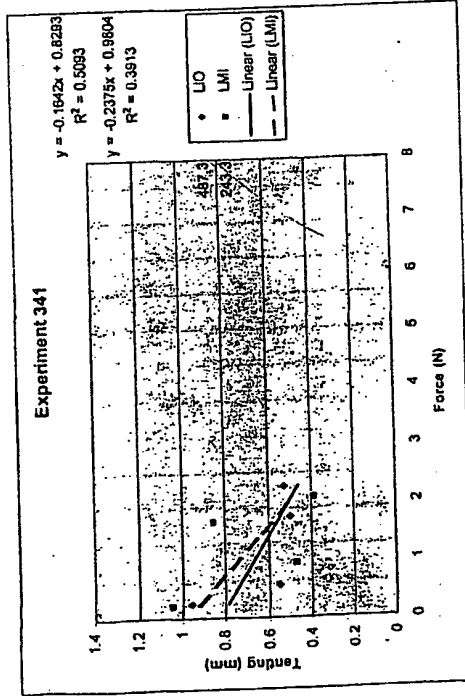
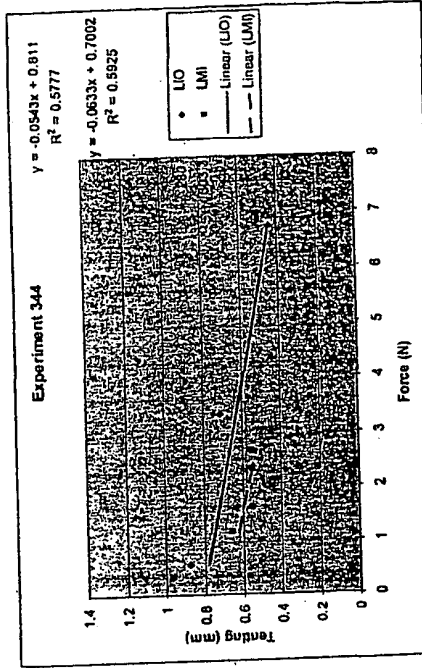
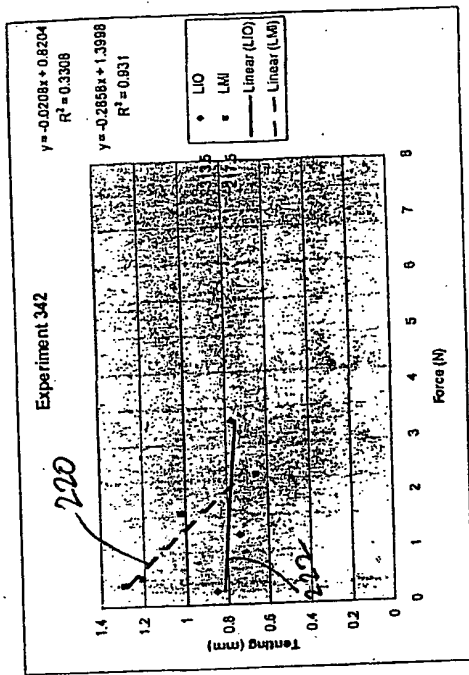
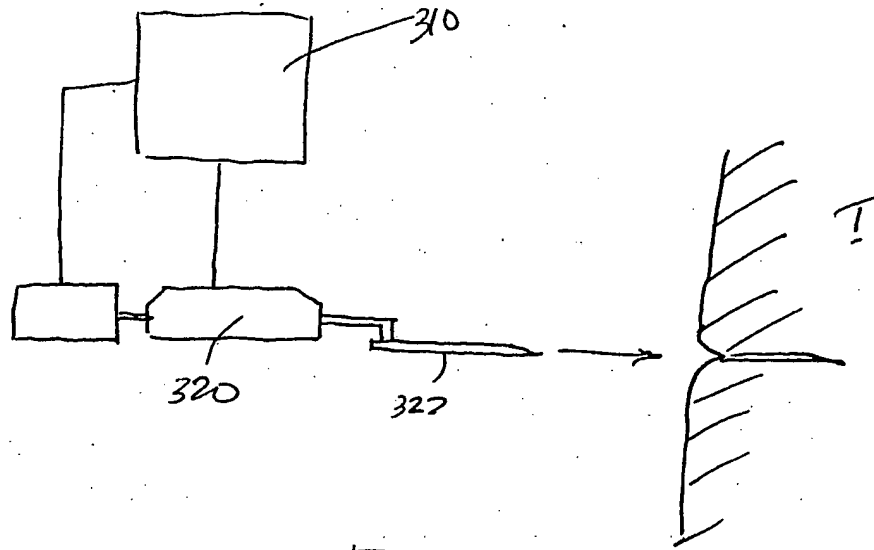

FIG-7



FIG_8

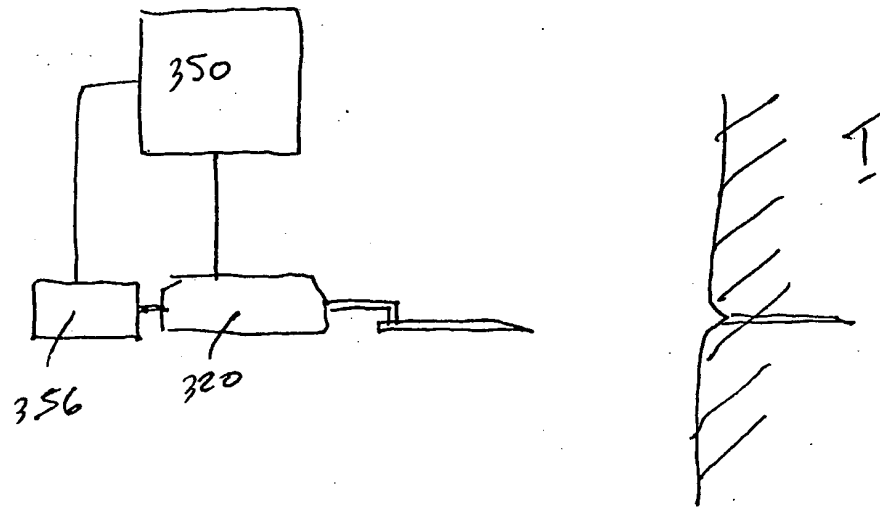

FIG-9

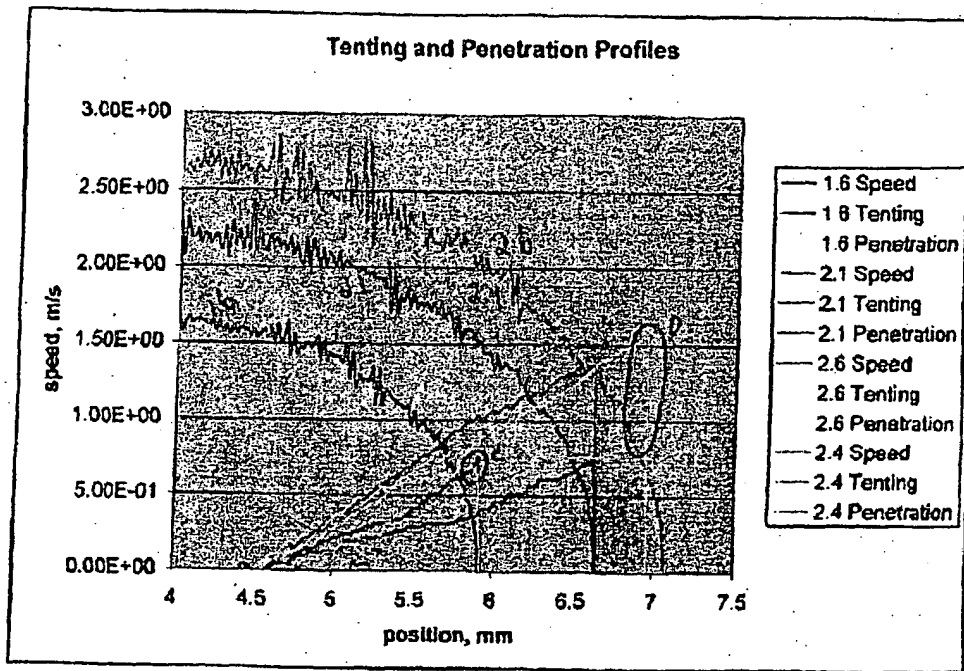

FIG-10

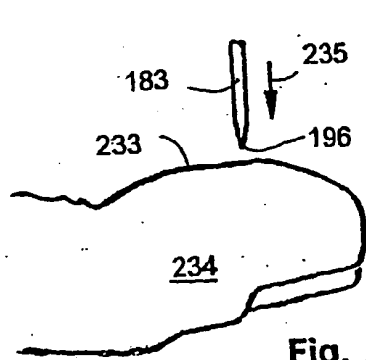

Fig. 11A

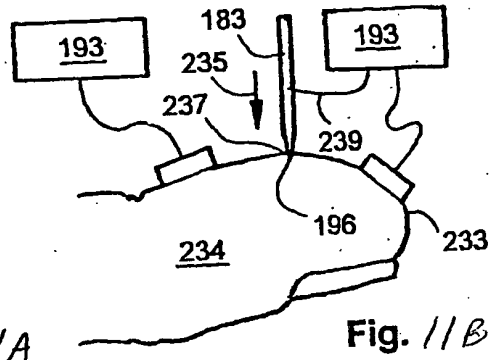

Fig. 11B

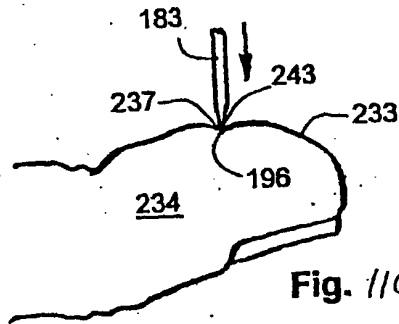

Fig. 11C

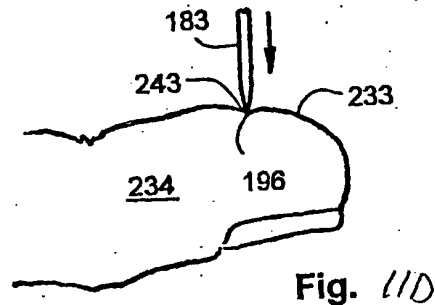

Fig. 11D

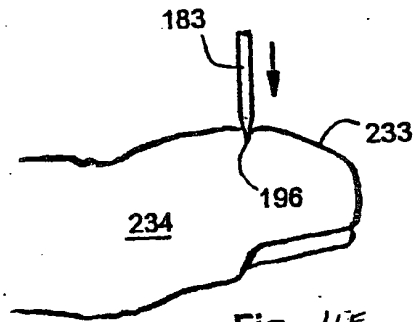

Fig. 11E

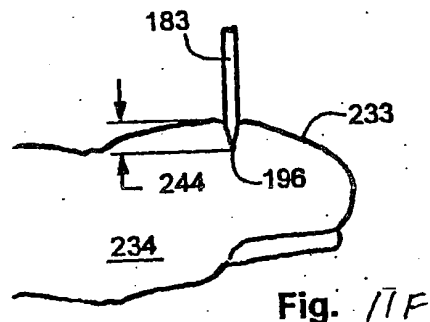

Fig. 11F

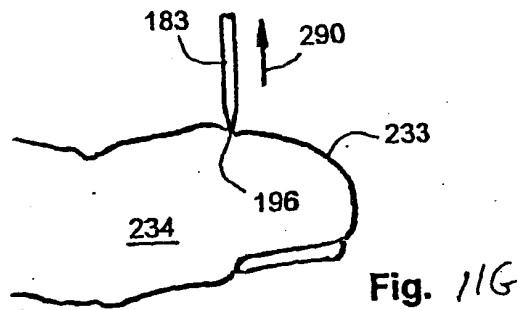

Fig. 11G

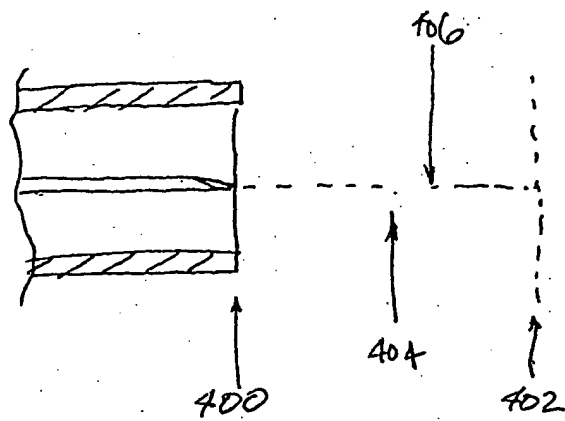

FIG-12A

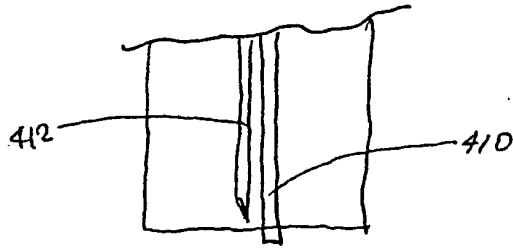

FIG-12B

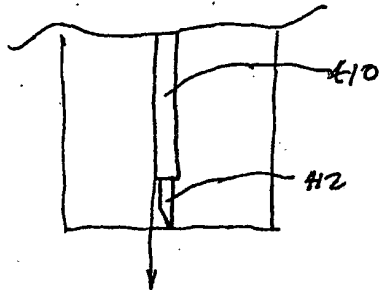

FIG-12C

14/45

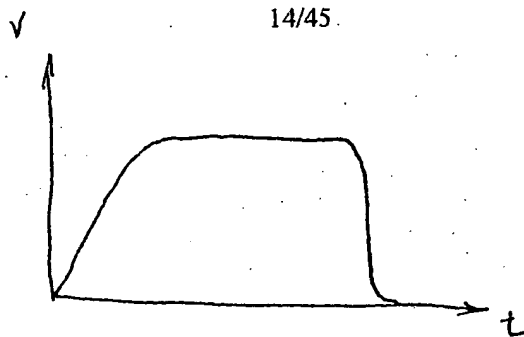

FIG-13

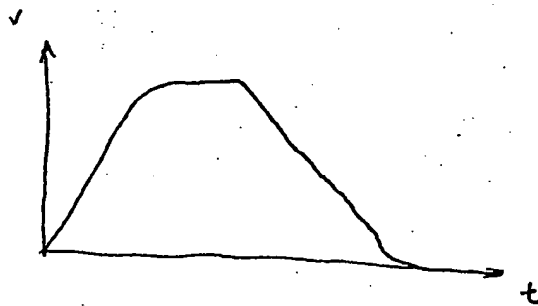

FIG-14

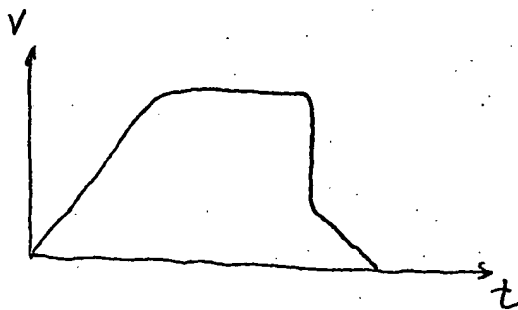

FIG-15

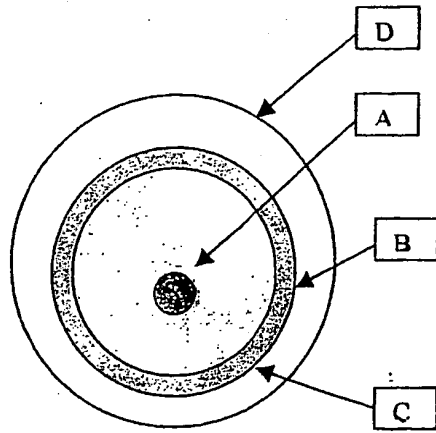

FIG-16

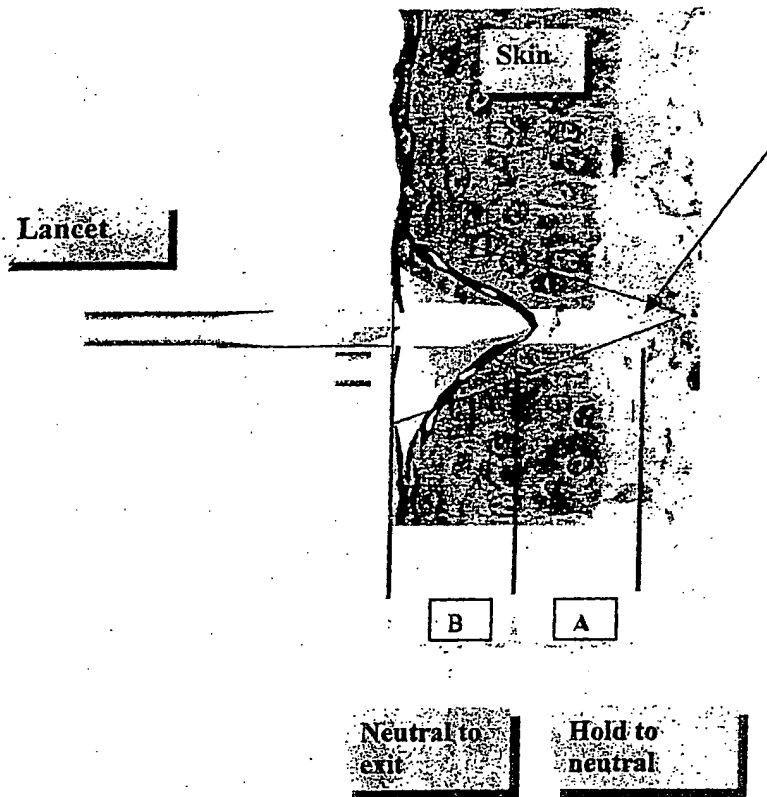
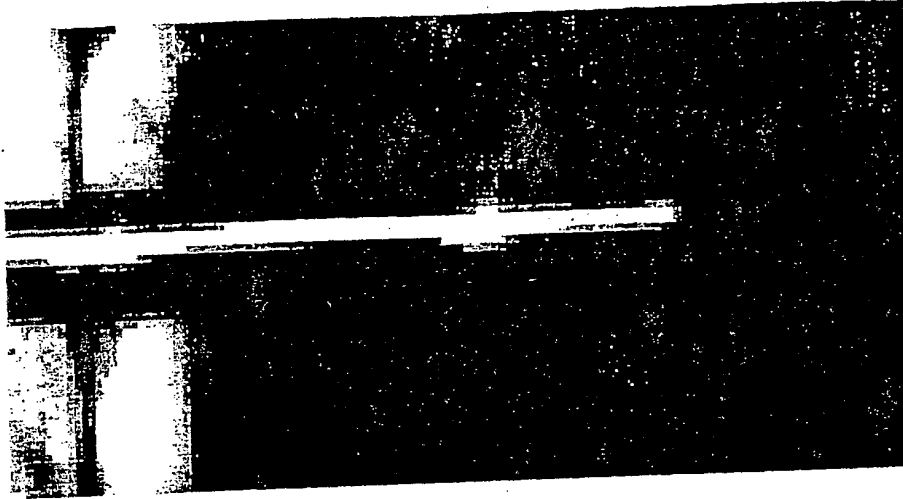

FIG-17



f-10-18

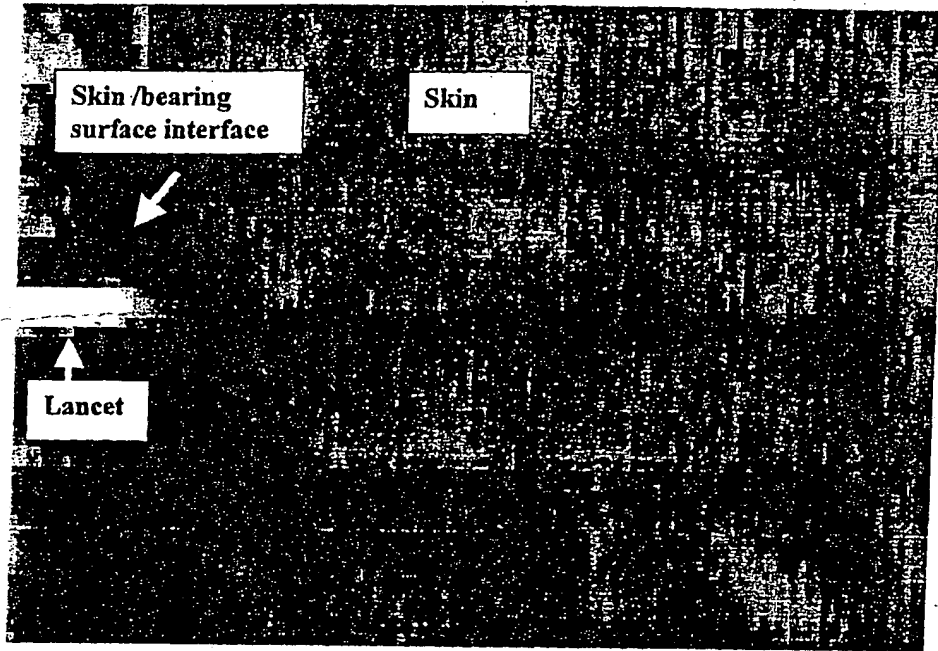

FIG-19

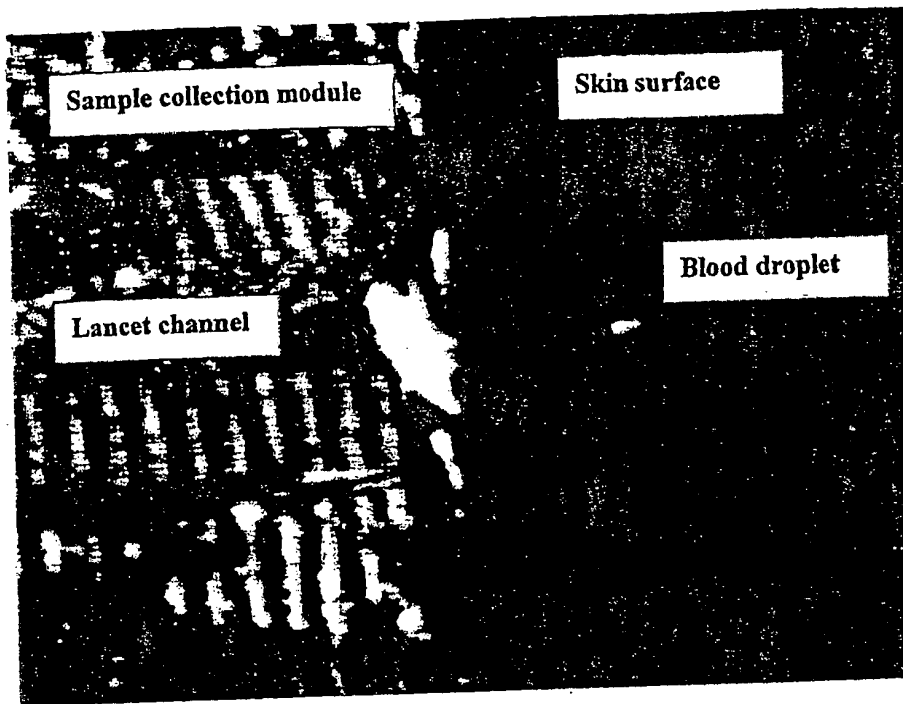

FIG-20

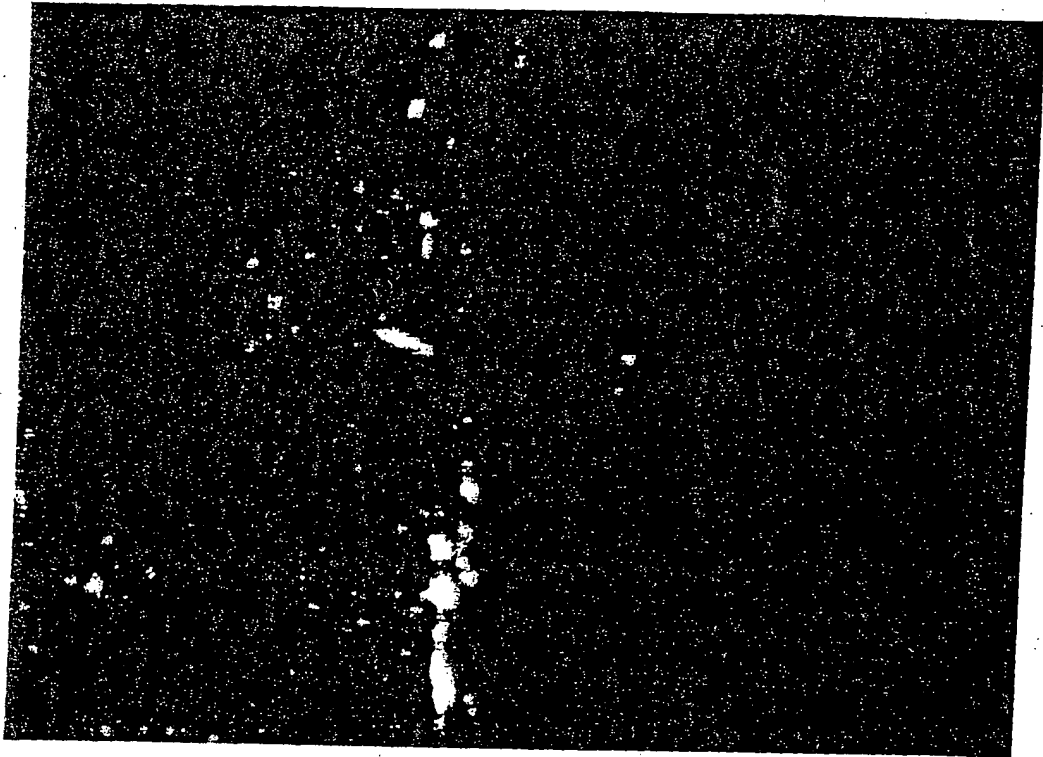

FIG-21

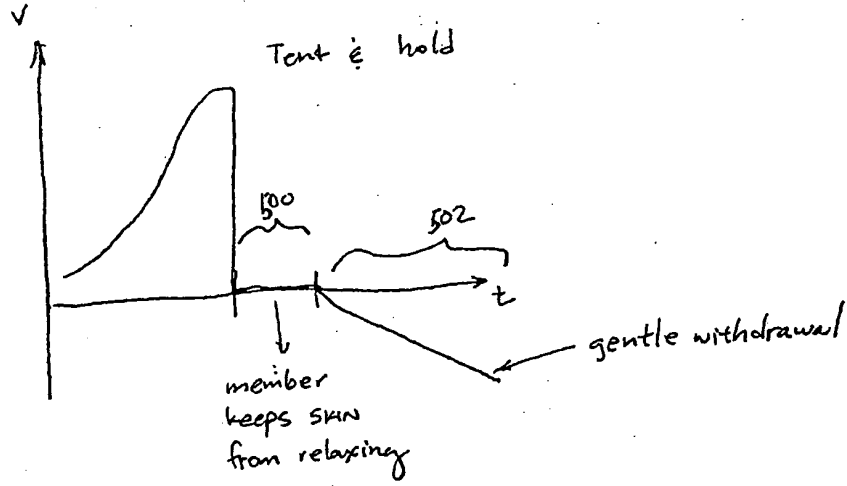

FIG-22A

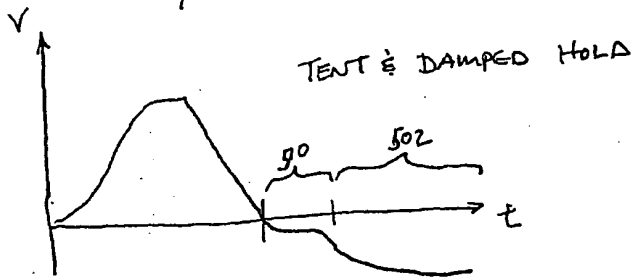

FIG-22B

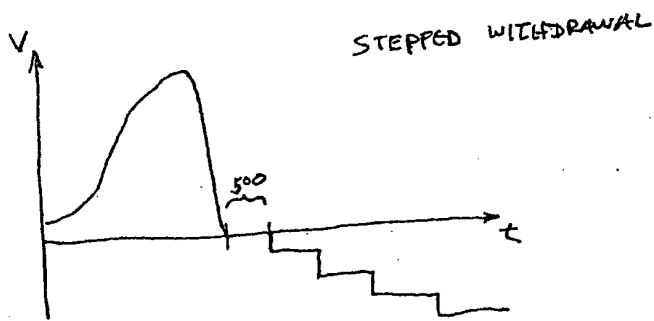

FIG-22C

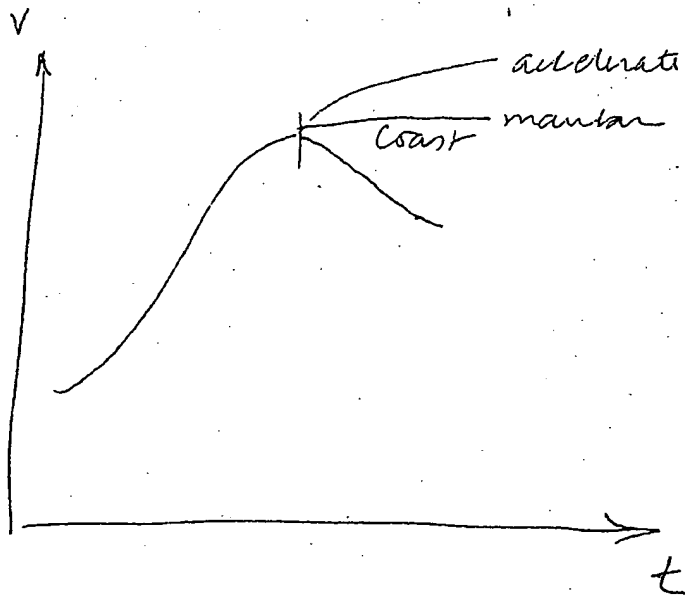
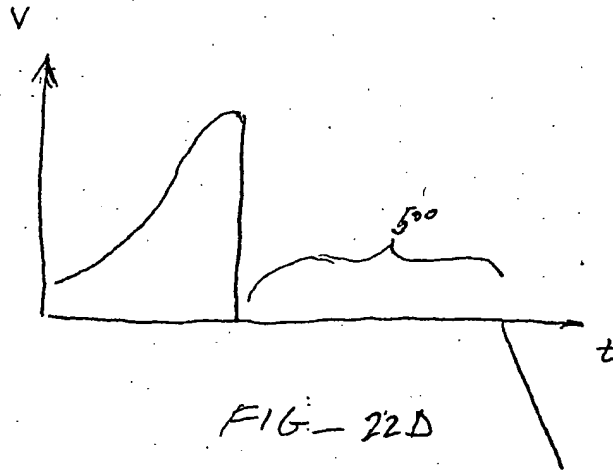

FIG - 23

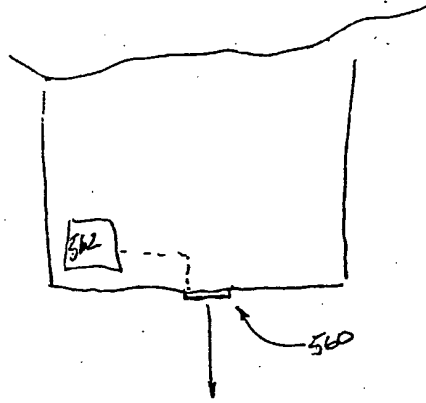

FIG- 24

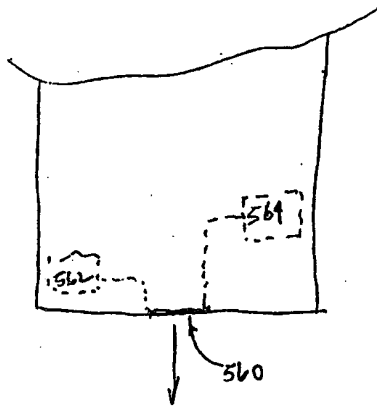

FIG- 25

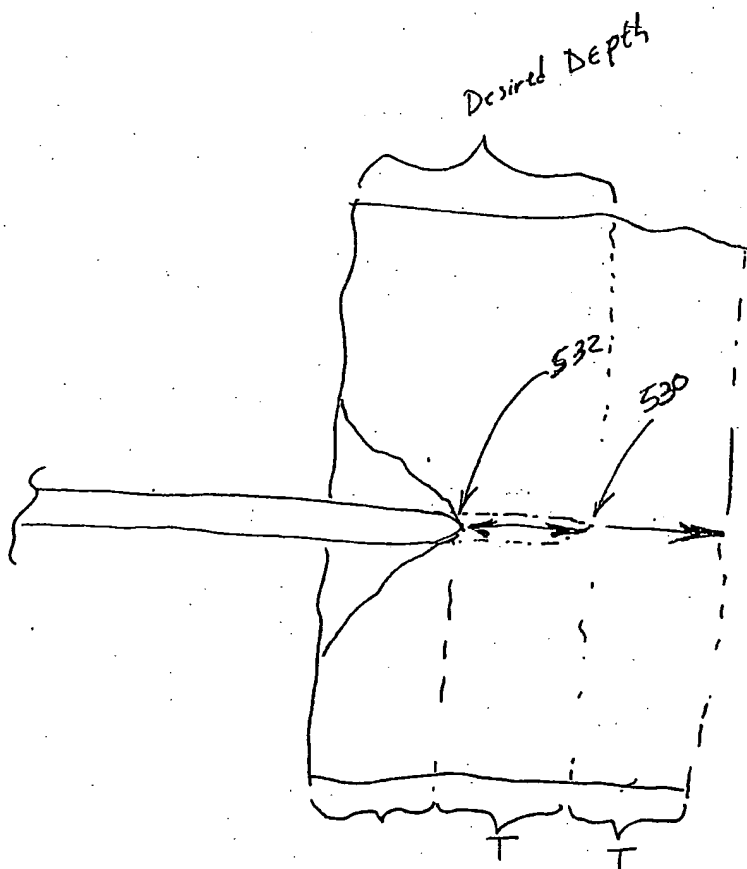

FIG - 26

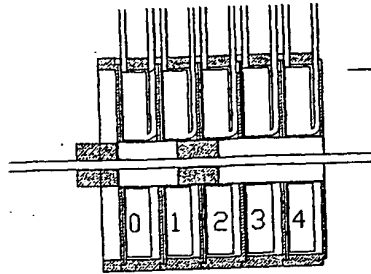

FIG - 27

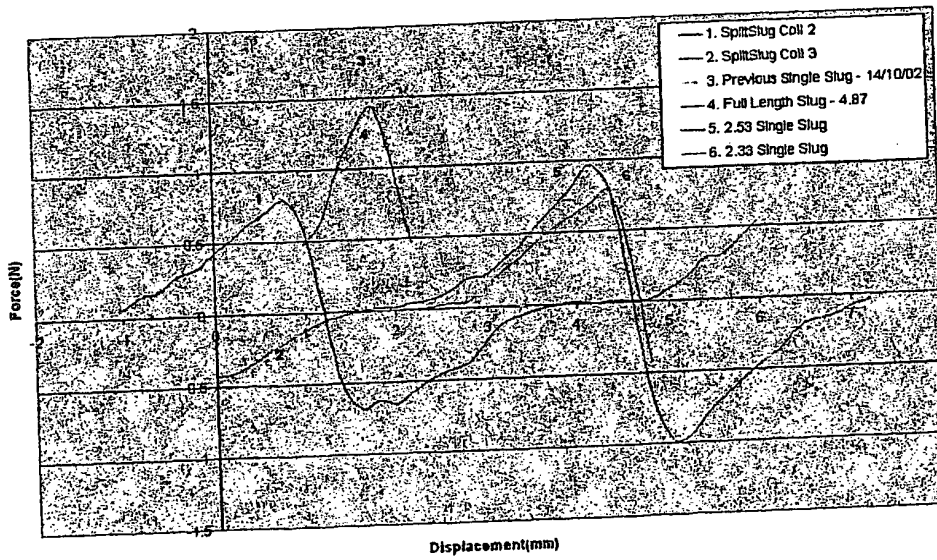

FIG - 28

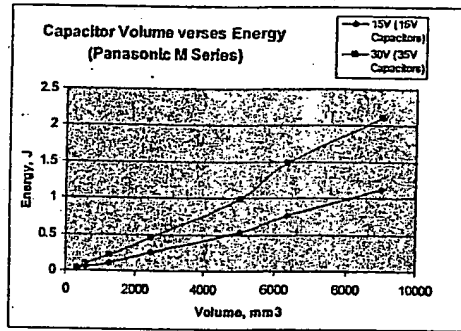

FIG-29

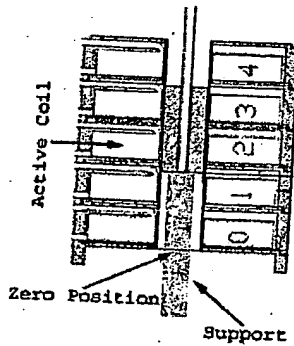

FIG-30

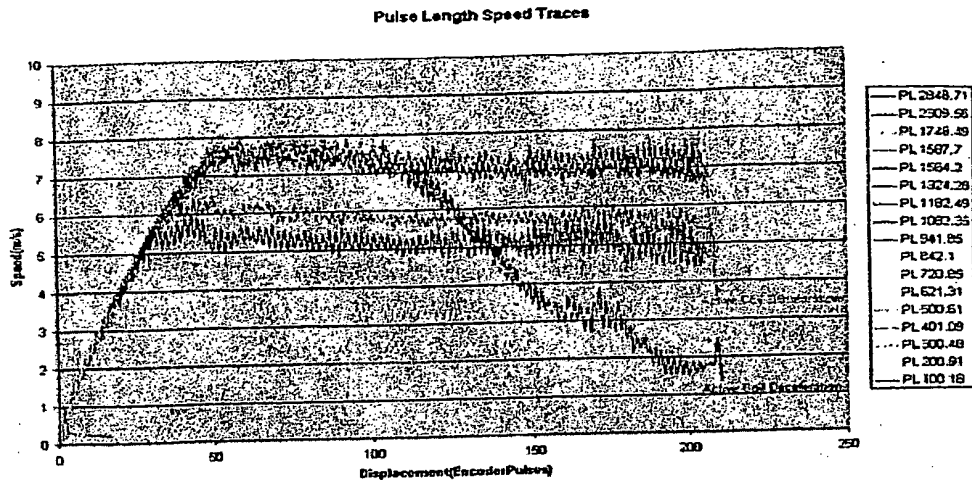

FIG-31

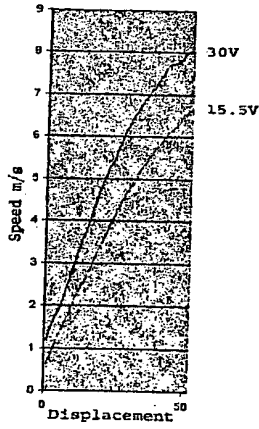

FIG-32

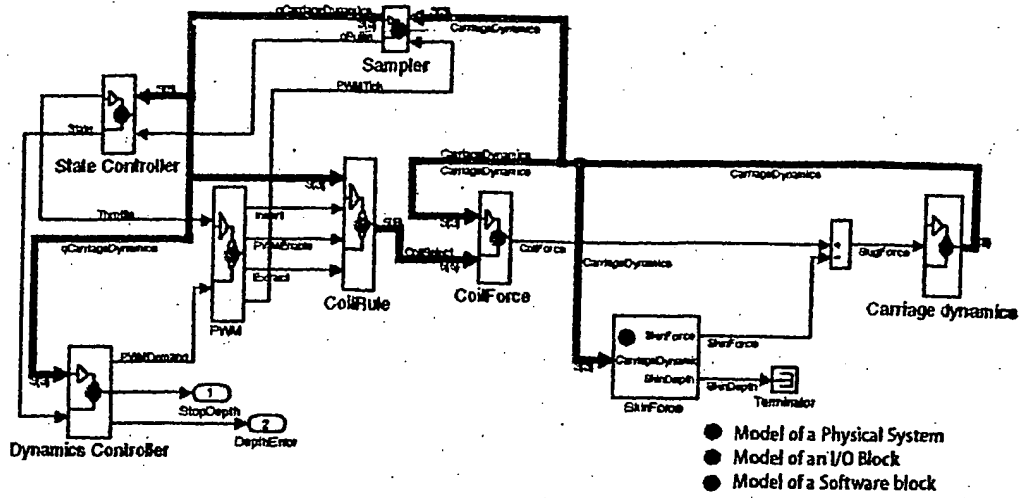

FIG-37

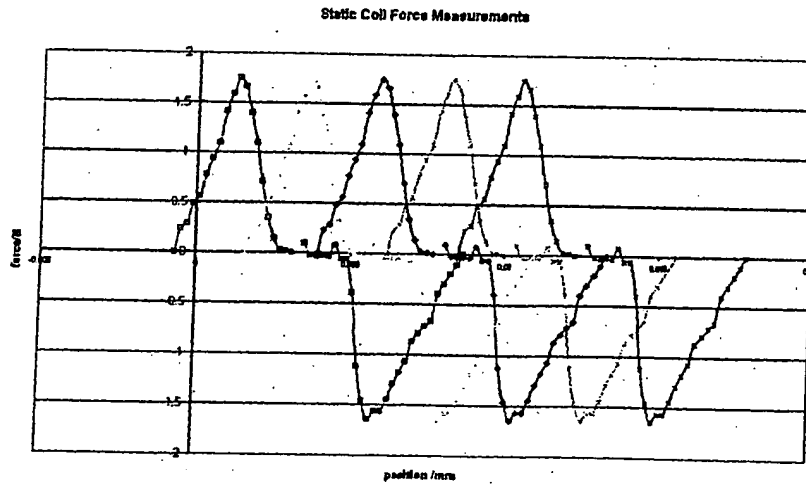

FIG-7A

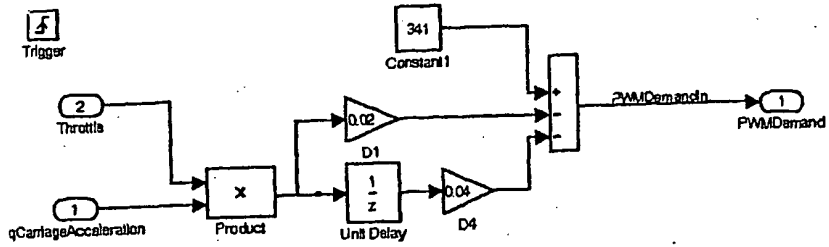

FIG-35

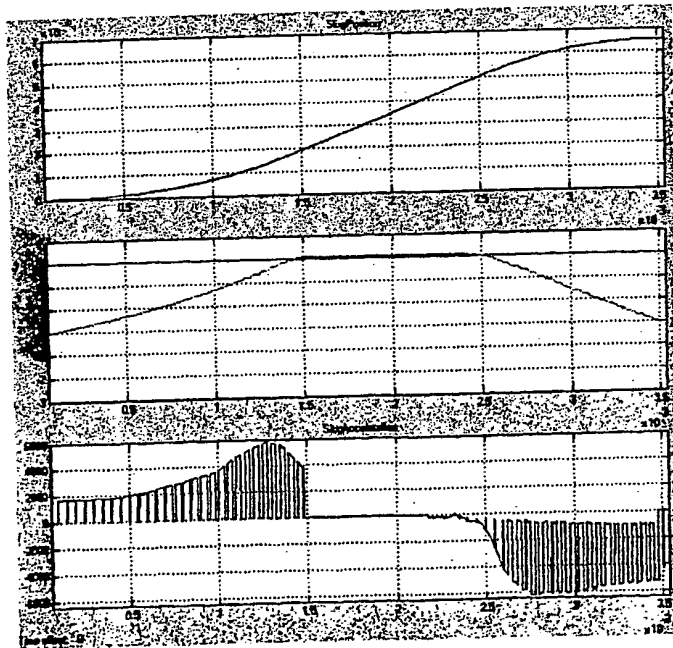

FIG-36

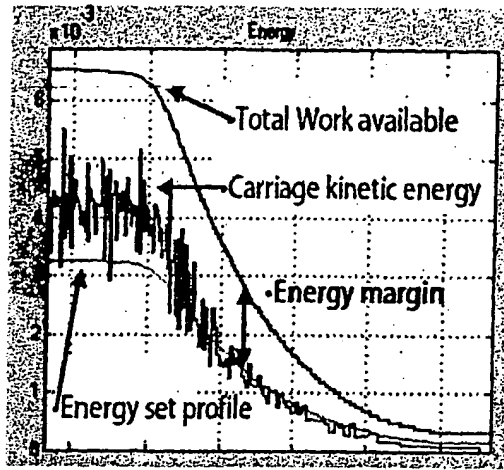

FIG-37

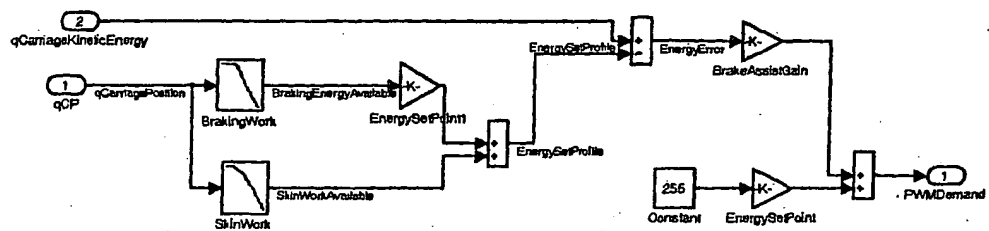

FIG-38

Sensitivity to variation

Controller		I/O system		Physical system	
	Controller EntrySpeed EnergySetPoint BrakeAssistGain LUT Resolution Under design control	Encoder Resolution Noise Under design control, variable in mfr	Carriage Mass InitialPosition LimitPosition Under design control	Launcher stiction pull-out force dynamic friction Known, variable in mfr	
Skin model force gain noise offset stiction Under design control, experimentally based	Coil model Peak force Centre Coil switch points Under design control, experimentally based	PWM Period Resolution Force rise time Under design control	Coil Peak force Centre Coil switch points Force rise time Under design control, variable in mfr	Skin force gain noise offset stiction Unknowns - variable in use	

bold modelled in sensitivity analysis
 italic variable - not yet modelled
 plain text under design control

FIG - 39

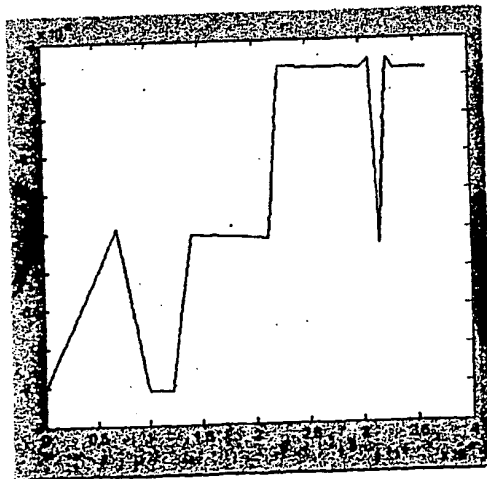

FIG - 40

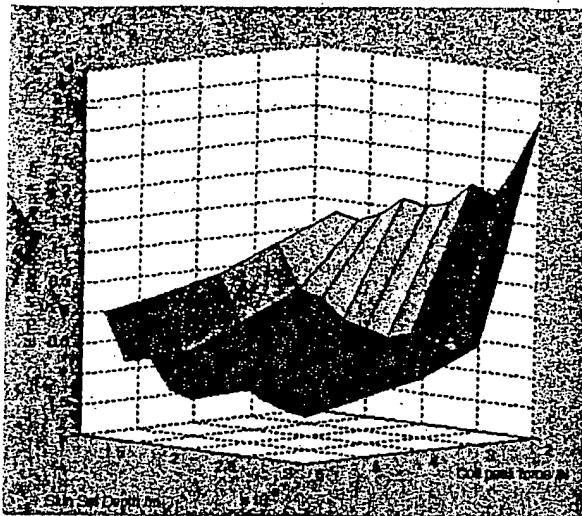

FIG - A1

Coil Usage

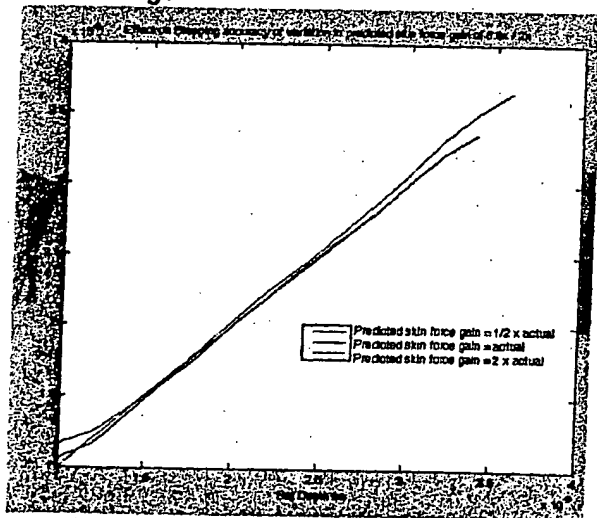

FIG - A2

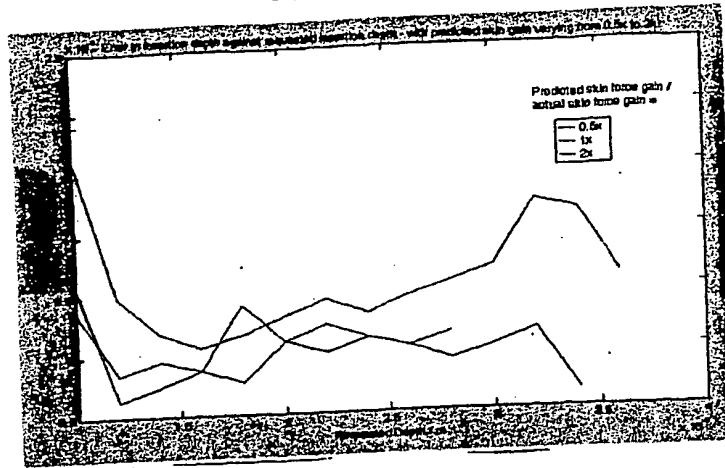
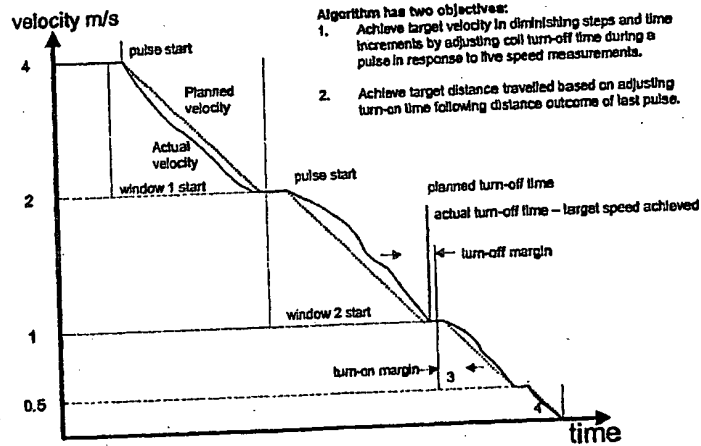

FIG-43



Algorithm has two objectives:

1. Achieve target velocity in diminishing steps and time increments by adjusting coil turn-off time during a pulse in response to five speed measurements.
2. Achieve target distance travelled based on adjusting turn-on time following distance outcome of last pulse.

1. In 1st pulse, distance travelled is less than predicted, so pulse 2 start is delayed
2. During pulse 2, distance travelled is greater than predicted, so pulse 3 is brought forward, using some of the turn-on margin
3. As pulses get shorter, potential final errors in distance reduce
4. Coils are pulsed 4-6 times, rather than hundreds of times. Conflict between PWM frequency and accuracy is resolved

FIG-44

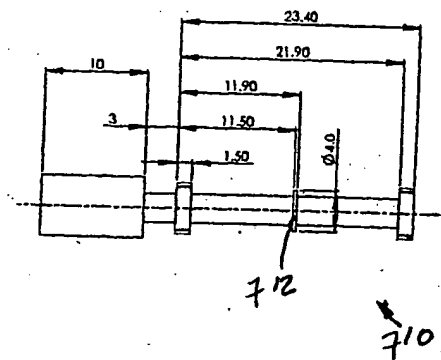

FIG-45

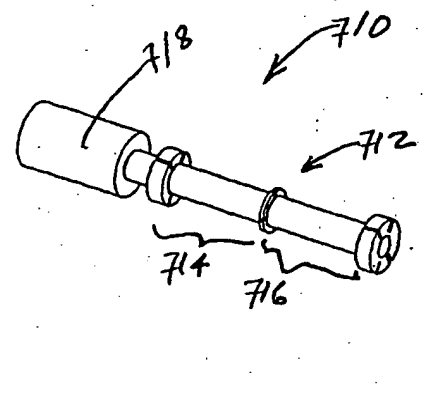
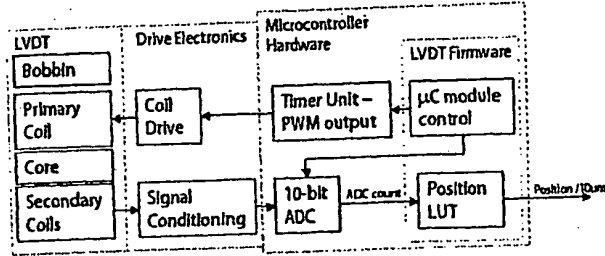

FIG-46



sch
mod
relat
figur

FIG-47

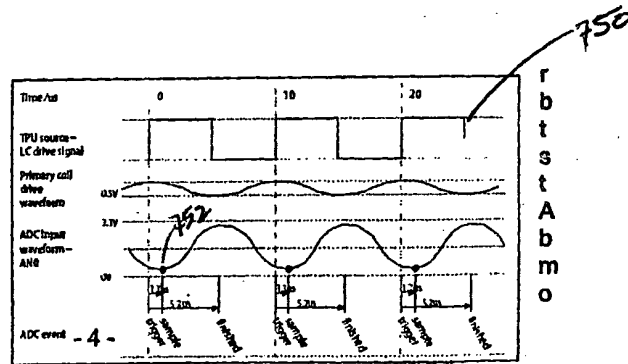

FIG-48

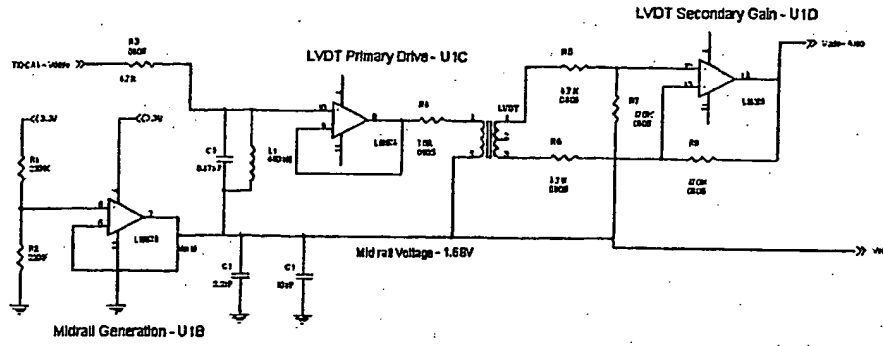

FIG - 49

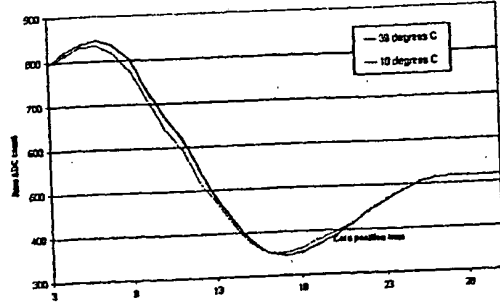

FIG-50

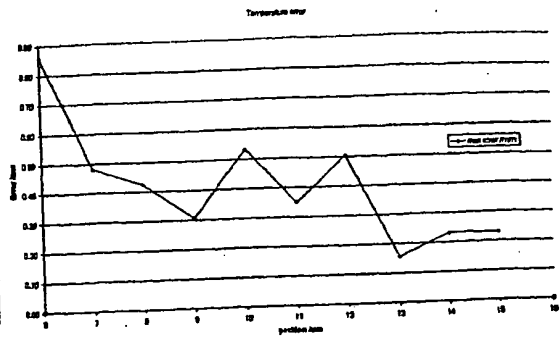

FIG-51

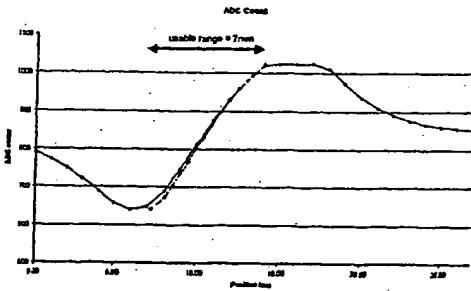

FIG-52

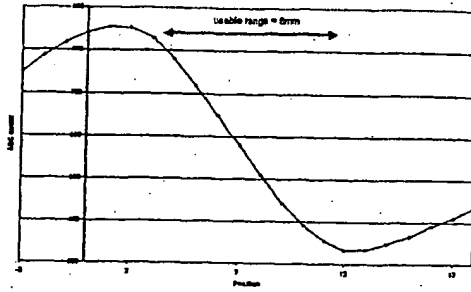

FIG-53

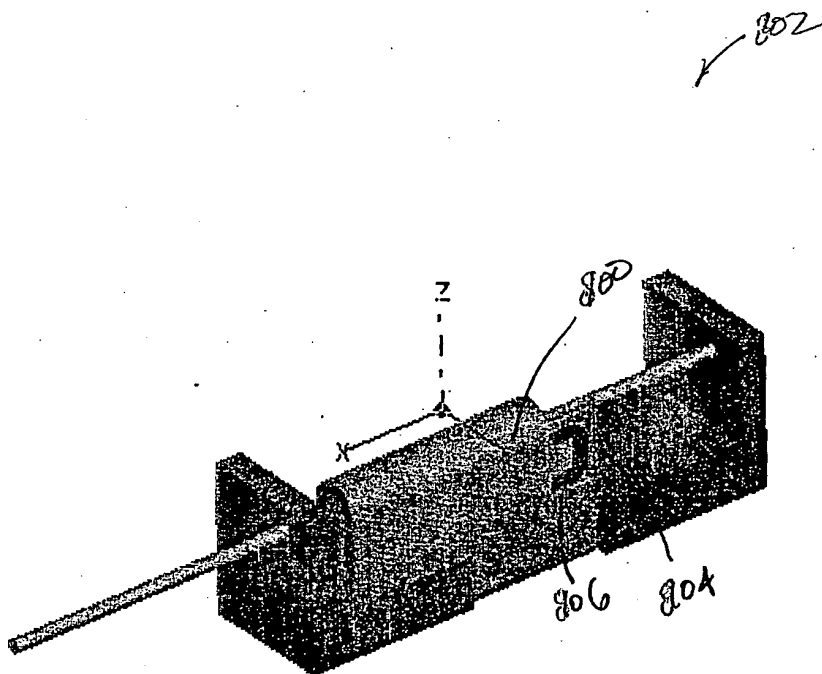

FIG-5A

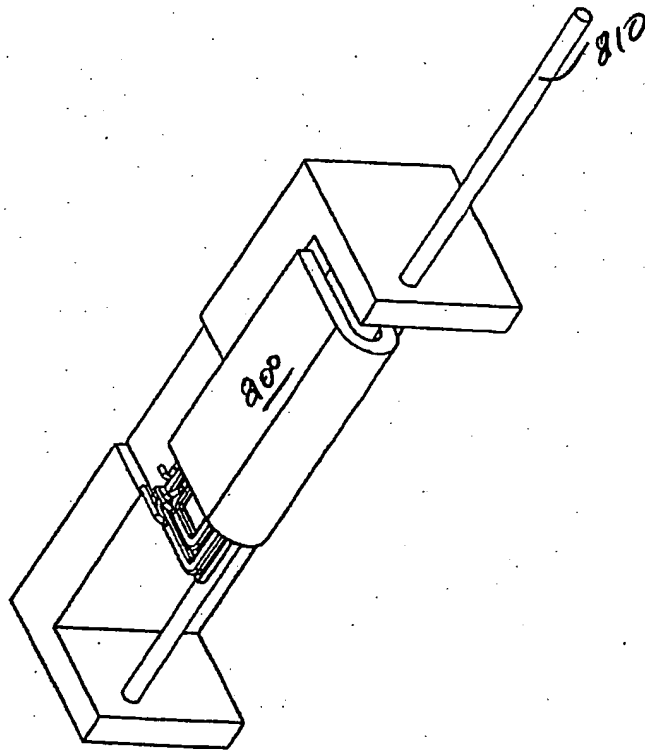

FIG-53

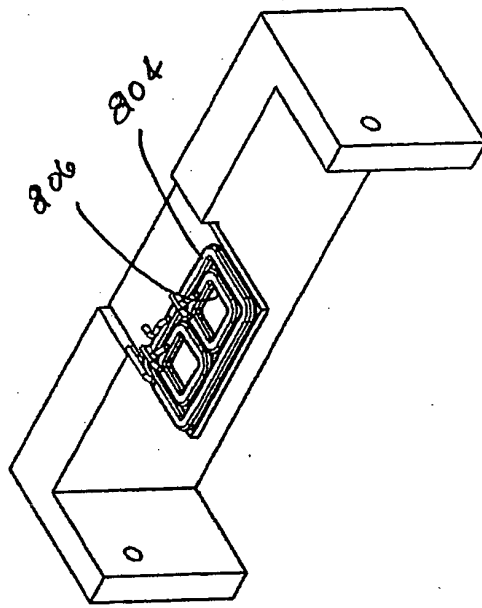

FIG-36

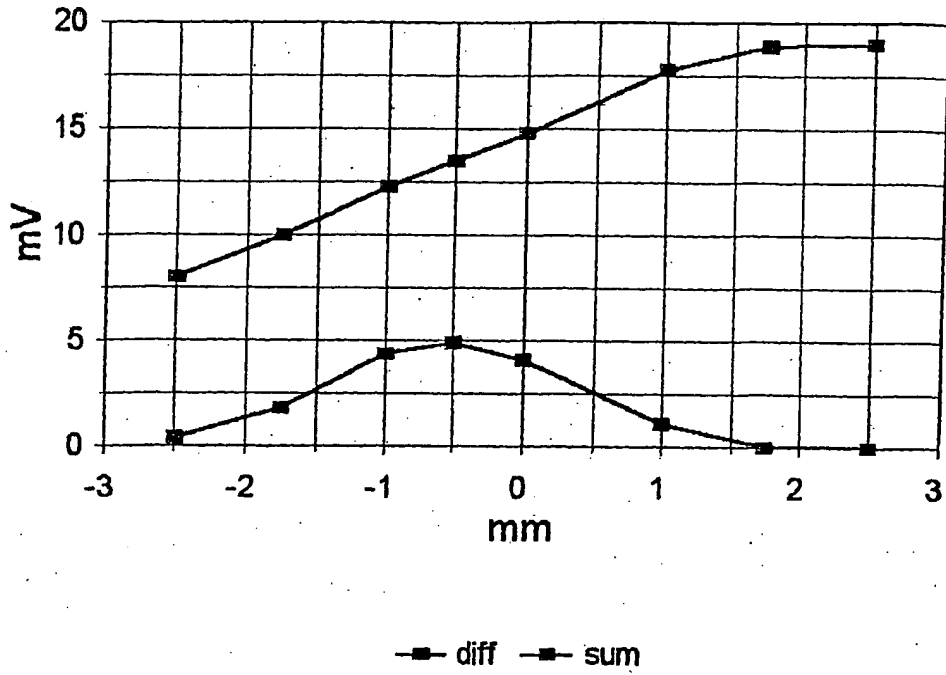

FIG-57

6000 Hz

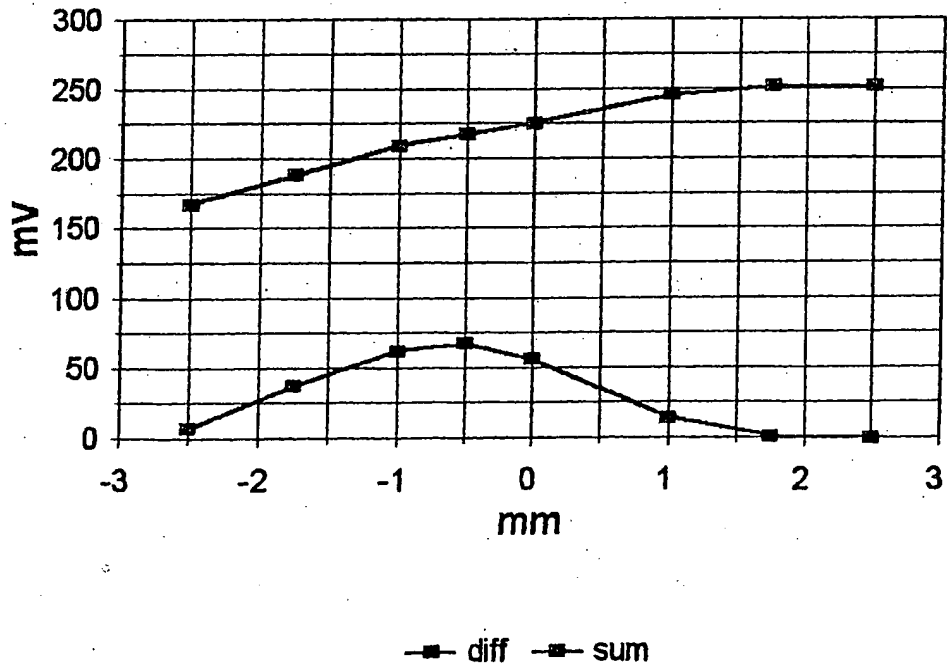

FIG-58

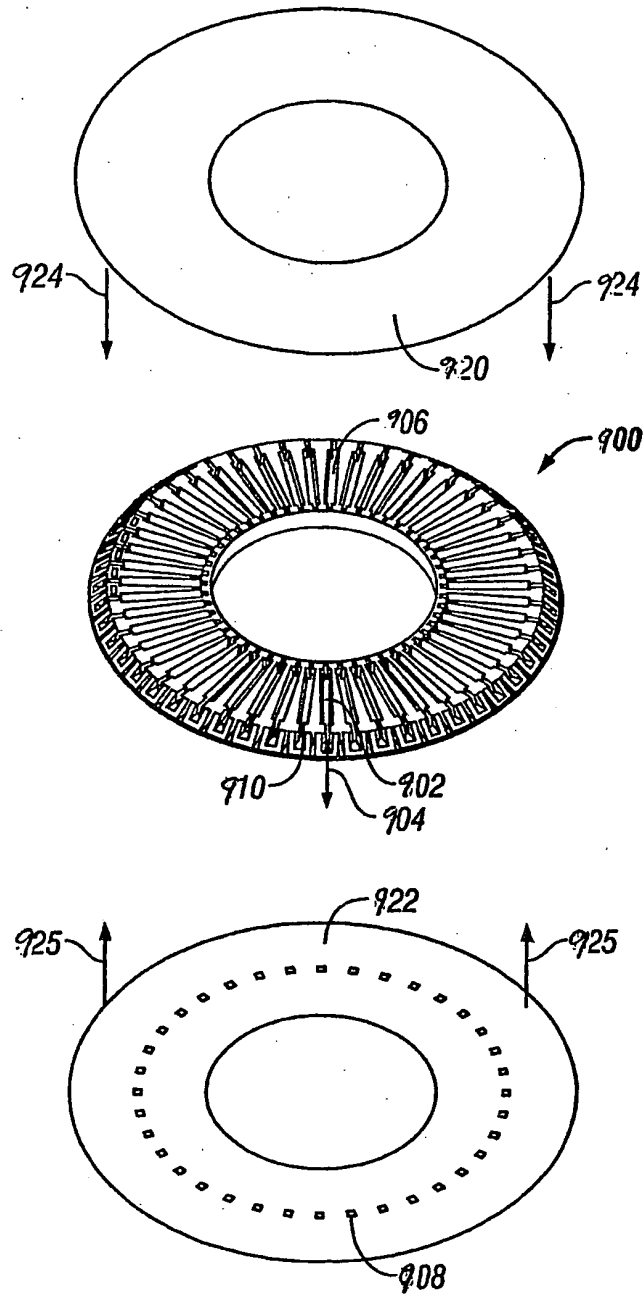

FIG. 59

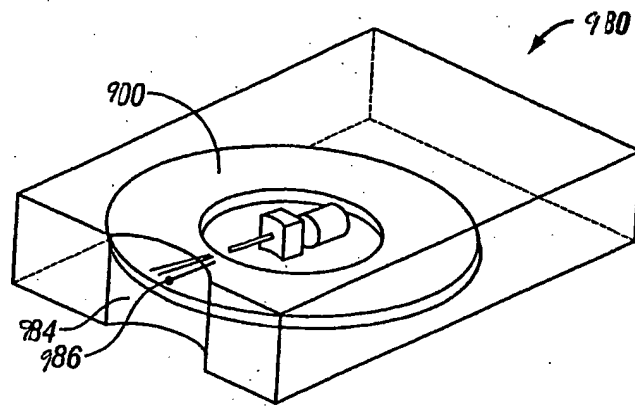

FIG-60

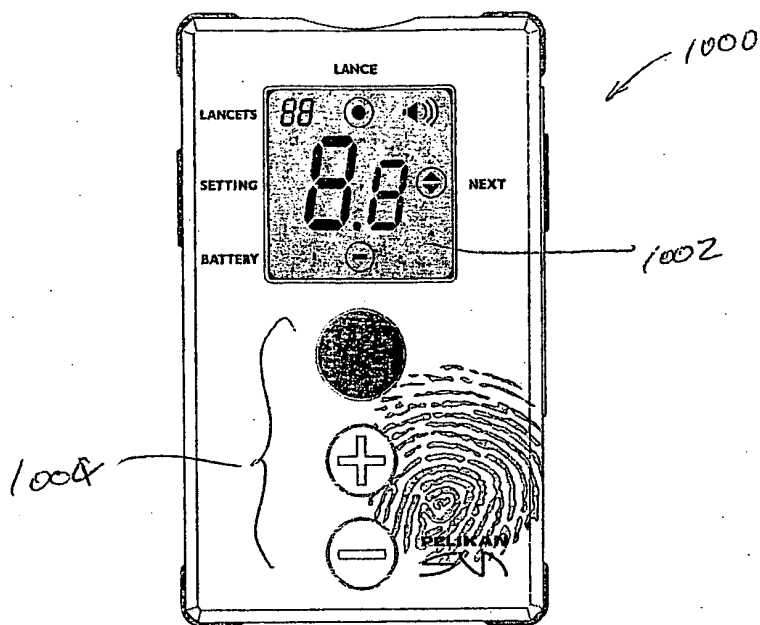

FIG-61

**This Page is Inserted by IFW Indexing and Scanning
Operations and is not part of the Official Record**

BEST AVAILABLE IMAGES

Defective images within this document are accurate representations of the original documents submitted by the applicant.

Defects in the images include but are not limited to the items checked:

- BLACK BORDERS
- IMAGE CUT OFF AT TOP, BOTTOM OR SIDES
- FADED TEXT OR DRAWING
- BLURRED OR ILLEGIBLE TEXT OR DRAWING
- SKEWED/SLANTED IMAGES
- COLOR OR BLACK AND WHITE PHOTOGRAPHS
- GRAY SCALE DOCUMENTS
- LINES OR MARKS ON ORIGINAL DOCUMENT
- REFERENCE(S) OR EXHIBIT(S) SUBMITTED ARE POOR QUALITY
- OTHER: _____

IMAGES ARE BEST AVAILABLE COPY.

As rescanning these documents will not correct the image problems checked, please do not report these problems to the IFW Image Problem Mailbox.

BLANK PAGE